

# INFORMATION FOR BUILDING CONSULTANTS AND CABLING PROVIDERS



## Telstra Requirements for Customer MDFs

This publication has been prepared and written by Telstra Corporation Limited (ABN 33 051 775 556), and is the subject of copyright. Other than for the purposes of and subject to the conditions prescribed under the Copyright Act, no part of it may in any form or by any means (electronic, mechanical, microcopying, photocopying, recording or otherwise) be reproduced, stored in a retrieval system or transmitted without prior written permission of Telstra. Product or company names are trademarks or registered trademarks of their respective holders.

Note for non-Telstra readers: The contents of this publication are subject to change without notice. All efforts have been made to ensure the accuracy of this publication. Notwithstanding, Telstra Corporation Limited does not assume responsibility for any errors nor for any consequences arising from any errors in this publication.

### Purpose

This document sets out Telstra's requirements for main distribution frames (MDFs) installed in customer premises ("customer MDFs") for termination of Telstra copper twisted pair lead-in cables. Some practical guidance is also provided on the installation and use of customer MDFs.

This document and related Telstra documents may be downloaded from the Telstra Smart Community® web site [www.telstra.com.au/smartcommunity/](http://www.telstra.com.au/smartcommunity/) (look under "Builders").

### Scope

This document applies to the initial installation and any subsequent augmentation of a customer MDF at business or residential premises.

### Interpretation

The MDF must meet ACMA\* compliance labelling requirements and must be installed in accordance with the requirements of the ACMA Wiring Rules (AS/ACIF S009:2006). The ACMA requirements are summarised in this document. The MDF must also meet Telstra's requirements as set out in this document. Telstra will not connect its lead-in cabling to any customer MDF that does not meet ACMA and Telstra requirements.

Notes:

1. The ACMA wiring rules (Australian Standard AS/ACIF S009:2006) may be downloaded free of charge from the Communications Alliance web site [www.commsalliance.com.au](http://www.commsalliance.com.au).
2. Other relevant standards are:
  - AS/NZS 3084, "Telecommunications installations — Telecommunications pathways and spaces for commercial buildings"
  - AS/NZS 3085.1, "Telecommunications installations — Administration of communications cabling systems — Basic requirements"
  - AS/NZS 3080, "Telecommunications installations — Generic cabling for commercial premises".

In this document:

- Mandatory requirements are denoted by use of the verbs "shall" and "must".
- Use of the verb "should" describes something that is desirable but not always practical.
- Paragraphs boxed like this contain important requirements, precautions or information.

© Registered trade mark of Telstra Corporation Limited ABN 33 051 775 556

\* Australian Communications and Media Authority [www.acma.gov.au](http://www.acma.gov.au)

## What is an MDF?

A customer MDF is a “distributor” that terminates, or is intended to terminate, a carrier’s twisted pair lead-in cabling at the customer’s building. A distributor (known previously as a “distribution frame”) is used to connect cables that run to different parts of the building from a common point and provides for cross-connection of cables by means of jumpers or patch cords. Not all distributors are MDFs but all MDFs are distributors.

There may be more than one MDF in a building (e.g. for termination of different carriers’ networks or separate twisted pair lead-in cables derived from different technologies).

A customer MDF is supplied and installed by the builder’s, owner’s or customer’s cabling provider as part of the building telecommunications cabling.

The MDF has a “carrier side” and a “customer side” (commonly referred to as “A” side and “B” side). The “A” side contains the carrier’s lead-in cable terminations, and the “B” side contains the customer cabling terminations. Telstra supplies, installs and maintains the termination modules on the “A” side of the MDF for connection of Telstra network cables.

Cross-connections are made between the “A” side and the “B” side of the MDF using “jumpers”. A jumper is a pair of twisted, insulated conductors that is connected to the termination modules using a tool designed for the purpose. Cross-connections in an MDF must **NOT** be made by means of patch cords or “pigtailed” (i.e. using plug-connected cords and sockets) for reasons explained on page 18.

An MDF is a defined network boundary point under section 22 of the Telecommunications Act 1997 and, where used, delineates between a carrier’s (e.g. Telstra’s) network and “customer cabling”. The MDF is the network boundary for all services supplied through it to customers located in the same building at which the MDF is located. The precise location of the network boundary within the MDF is the jumper terminations on the customer side of the MDF, i.e. “the side of the frame nearest to the end-user”.

The functional elements of a customer MDF are illustrated in Figure 1.

## What is NOT an MDF?

MDFs are only defined in AS/ACIF S009 for connection of twisted pair lead-in cables and not for coaxial or optical fibre lead-in cables. Any device used to connect coaxial or optical fibre lead-in cable is **NOT** an MDF. However, coaxial or optical connections may be included on the customer side of the MDF (e.g. for connection of coaxial or optical fibre customer cabling to other coaxial or optical fibre customer cabling).

Any device that interconnects cables without jumpers (or patch cords) is not a distributor and, therefore, cannot be an MDF.

Any device that is not located in or on a building (e.g. a freestanding device such as a cabinet or pillar) is **NOT** an MDF.

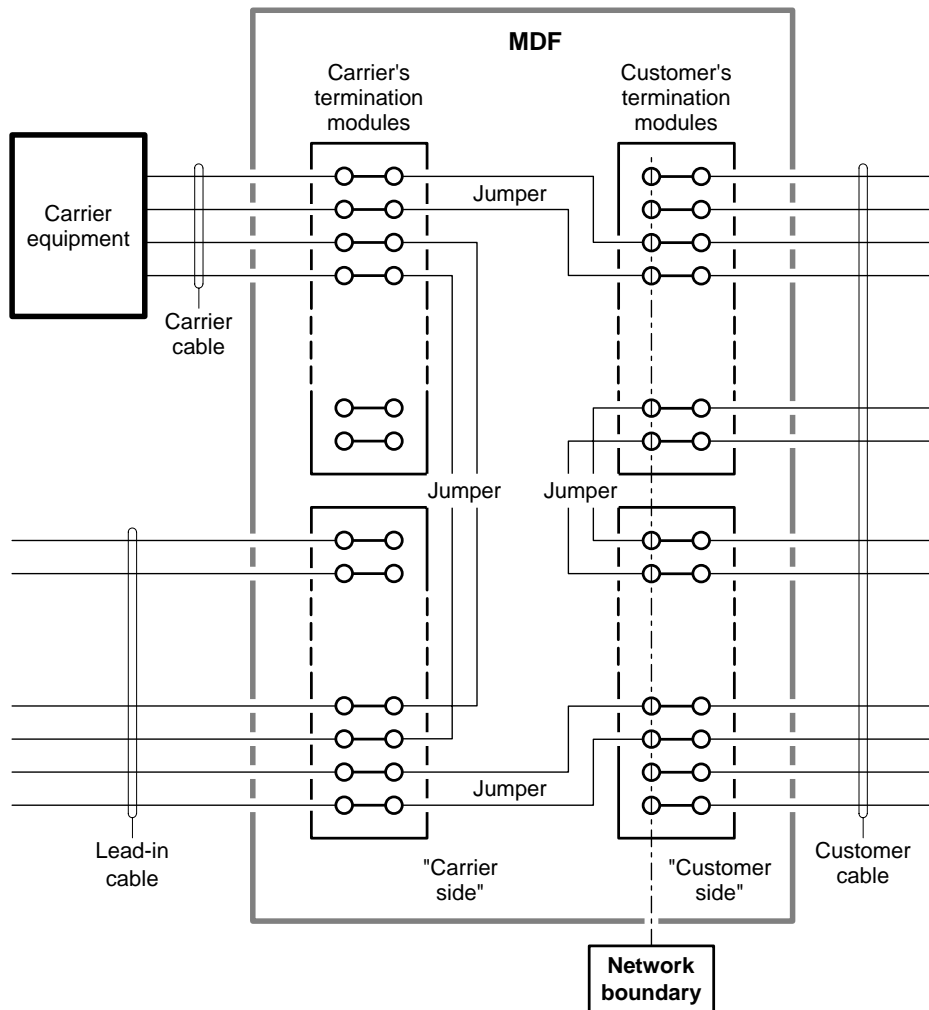

Figure 1 Functional elements of a customer MDF  
[Figure J.15 of AS/ACIF S009:2006]

## When is an MDF required?

Telstra considers that a customer MDF is required in one or more of the following circumstances:

- two or more carriers will supply services to the building and share the customer cabling
- two or more customers will occupy the building
- the total capacity of the lead-in cabling will be ten (10) pairs or greater (except in the case of a 10-pair lead-in cable to a home or small business in a rural area — see Note 1)
- more than four (4) network lines are to be connected initially (Note 2)
- more than eight (8) telecommunications outlet cables are to be connected initially (Note 2).

Notes:

1. 10-pair cable is Telstra's standard size lead-in cable for rural areas. While a 10-pair rural lead-in cable may terminate on a Telstra NTD, a 10-pair urban lead-in cable should be terminated on a customer MDF.
2. Telstra's Network Termination Device (NTD) will connect up to six (6) lines and twelve (12) internal cables, which may avoid the need for the use of an MDF in some cases. However, use of this NTD for new installations is limited to four (4) lines and eight (8) internal cables to allow room for expansion. See Telstra Specification 012688.

Telstra does not normally accept responsibility for cabling on the customer side of the MDF but may use such cabling to supply a telecommunications service to the point where the customer requires it.

# ACMA requirements for customer MDFs

## General

The MDF must comply with ACMA requirements set out in Australian Standards AS/ACIF S008:2006 (customer cabling products) and AS/ACIF S009:2006 (wiring rules). These requirements are summarised below.

Note: Because the MDF is a distributor, it must meet the ACMA requirements for all distributors (per section 12 of AS/ACIF S009:2006) plus the additional MDF requirements (per section 13 of AS/ACIF S009:2006).

The relevant parts of AS/ACIF S008:2006 and AS/ACIF S009:2006 are indicated in brackets [ ].

Note: These standards may be downloaded free of charge from the Communications Alliance web site at <http://www.commsalliance.com.au/documents/standards>.

## Location

- (a) The proposed location of the MDF should be discussed with the carrier (e.g. Telstra) prior to installation. [AS/ACIF S009:2006 Clause 13.3, Note]
- (b) The MDF should not be located in the same room as any HV electrical equipment. [AS/ACIF S009:2006 Clause 9.1.3.1 Note 2]
- (c) The MDF should be located near the LV electrical switchboard to enable bonding/earthing of surge suppression devices within the conductor length limits described in AS/ACIF S009:2006 (1.5 m/10 m — see pages 24 and 25 of this document). [AS/ACIF S009:2006 Clause 13.3 (a)]
- (d) The MDF shall be structurally robust and shall be securely attached to a permanent building element such as a wall, floor or column (mounting on hinged panels or wheeled trolleys is not permitted). [AS/ACIF S009:2006 Clauses 13.2 (b), 13.3 (c)]
- (e) Any MDF installed inside the building shall be installed in a position free from the ingress of dust and moisture and which is not subject to damp and/or humid conditions. [AS/ACIF S009:2006 Clause 13.3 (b)]
- (f) The MDF shall not be installed in any of the following locations:
  - in any room containing washing, shower or toilet amenities [AS/ACIF S009:2006 Clause 13.4 (a)]
  - in a boiler, plant or machine room [AS/ACIF S009:2006 Clause 13.4 (b)]
  - in any area subject to corrosive fumes or fluids [AS/ACIF S009:2006 Clause 13.4 (c)]
  - in a fire escape stairway [AS/ACIF S009:2006 Clause 13.4 (d)]
  - near an automatic sprinkler unless the MDF is provided with a shield to prevent water falling on it, or all sprinkler heads that could project water onto the MDF have suitable deflectors, or the sprinkler heads are of the dry type [AS/ACIF S009:2006 Clause 13.4 (e)]
  - within a cupboard containing a fire hose reel [AS/ACIF S009:2006 Clause 13.4 (g)]
  - near a bath, shower, basin, tub or other fixed water container [AS/ACIF S009:2006 Clauses 7.2.2.2 (a) to (c), 13.4 (f)]
  - near a spa pool, spa tub or swimming pool [AS/ACIF S009:2006 Clauses 7.2.2.2 (d) and (e), 13.4 (f)]
  - near a fountain or water feature [AS/ACIF S009:2006 Clauses 7.2.2.2 (f), 13.4 (f)]
  - within a room or enclosure containing a sauna heater [AS/ACIF S009:2006 Clauses 7.2.2.2 (g), 13.4 (f)]
  - within a refrigeration room [AS/ACIF S009:2006 Clauses 7.2.2.2 (h), 13.4 (f)]
  - within the hosing down area of any location where general hosing down operations are carried out. [AS/ACIF S009:2006 Clauses 7.2.2.2 (i), 13.4 (f)]

## Enclosure

- (g) Cable entry holes shall be free of sharp edges or burrs or shall have a suitable grommet or insulating material fitted. [AS/ACIF S009:2006 Clauses 12.5 (a), 13.2 (a)]
- (h) The MDF enclosure shall be designed so as to prevent access to live parts by unqualified persons. [AS/ACIF S009:2006 Clauses 12.5 (c), 13.2 (a)]
- (i) The MDF enclosure shall be free of exposed sharp edges. [AS/ACIF S009:2006 Clauses 12.5 (d), 13.2 (a)]
- (j) The enclosure shall provide a minimum clearance of 30 mm between the carrier's termination modules and the inside face of the front cover or door of the enclosure in the fully closed position. [AS/ACIF S008:2006 Clause 5.4.2.4, AS/ACIF S009:2006 Clause 13.10]

## External (outdoor) MDF

- (k) If the MDF is exposed to the weather, it shall have a minimum degree of protection against the entry of water of IPX3 of AS 60529 or shall be enclosed in an enclosure assessed against the relevant clauses of AS/ACIF S008 and that provides a minimum degree of protection of IPX3. [AS/ACIF S009:2006 Clauses 12.4 (a), 13.2 (a)]
- (l) The MDF and the cables connected to it shall be installed in such a way that a minimum degree of protection of IPX3 of AS 60529 is maintained. [AS/ACIF S009:2006 Clauses 12.4 (b), 13.2 (a)]

## Security

- (m) The MDF or enclosure in which it is located shall have provision for securing with a key, lock or tool. [AS/ACIF S009:2006 Clause 13.5]
- (n) The building owner, manager or occupant is responsible for the security of the MDF. [AS/ACIF S009:2006 Clause 13.5 Note 2]
- (o) The MDF should be adequately secured against vandalism and access by children or unauthorised persons but reasonable access should be given to carriers, carriage service providers and cabling providers, as required. [AS/ACIF S009:2006 Clause 13.5 Note 2]

## Access

- (p) Adequate space shall be provided around the MDF where persons are to pass to enable safe and convenient access to the MDF and ready escape from the vicinity under emergency conditions. An MDF is deemed to comply with this requirement if it is installed in accordance with Appendix D of Australian Standard AS/ACIF S009:2006 (see Figures 2 to 4 of this document). [AS/ACIF S009:2006 Clause 13.6]
- (q) Any room containing the MDF shall not require the use of a tool, key, card, number pad or the like to exit the room. [AS/ACIF S009:2006 Clause 13.8]
- (r) The highest terminal or socket of a wall-mounted MDF (whether internal or external) shall not be greater than 1800 mm from finished ground or floor level. [AS/ACIF S009:2006 Clause 13.7.1]
- (s) The lowest terminal or socket of any external (wall-mounted) MDF shall not be less than 350 mm from finished ground or floor level. [AS/ACIF S009:2006 Clause 13.7.2.1]
- (t) The lowest terminal or socket of any internal (wall-mounted or floor-mounted) MDF should not be less than 350 mm from finished ground or floor level. [AS/ACIF S009:2006 Clause 13.7.2.2]

## Lighting

- (u) The MDF shall be provided with adequate lighting (a light intensity of 500 lux at a height of 1 metre above ground or floor level is considered to be adequate lighting). [AS/ACIF S009:2006 Clause 13.9]

## Marking

- (v) The MDF shall:
- have the verticals clearly marked alphabetically from left to right, omitting the letters “I” and “O”; and [AS/ACIF S009:2006 Clause 13.12 (a)]
  - have the range of jumperable terminations within each vertical indicated numerically in ascending order from the lowest module position (unless clearly labelled otherwise) starting from numeral “1”. [AS/ACIF S009:2006 Clause 13.12 (b)]
- Note: A partially equipped MDF should be marked so as to allow expansion of the MDF without the need to redesignate verticals or renumber existing terminations. [AS/ACIF S009:2006 Clause 13.12 Note]

## Earthing

- (w) Provision shall be made for any metallic enclosure, frame or backmount to be earthed (e.g. by providing suitable holes, screws, bolts or clamps for connection of earthing conductors). [AS/ACIF S009:2006 Clauses 12.5 (b), 13.2 (a)]

## Connections

- (x) The MDF shall be capable of terminating the carrier’s standard termination modules (ADC KRONE in Telstra’s case) on the carrier’s side of the MDF. [AS/ACIF S009:2006 Clause 13.11]
- (y) A carrier’s lead-in cabling or network boundary facilities shall not be moved, removed or altered without the prior written authorisation of the carrier. [AS/ACIF S009:2006 Clause 5.13]
- (z) A cabling provider shall not make a connection on the carrier side of the MDF unless a pair on the carrier side has been tagged, labelled, recorded or otherwise specified by the carrier for the customer service that is to be connected. [AS/ACIF S009:2006 Clause 13.13.1]
- (aa) A cabling provider may make or alter any connection on the customer side of the MDF. [AS/ACIF S009:2006 Clause 13.13.2]
- (bb) A cabling provider may remove a redundant cross-connection (“dead jumper”) from the carrier side of the MDF if all reasonable steps have been taken to ensure that a working service is not inadvertently disconnected. [AS/ACIF S009:2006 Clause 13.13.3]

## Records

- (cc) Suitable cable records shall be provided that enable cables and cross-connections to be correctly identified and connected. [AS/ACIF S009:2006 Clauses 12.3.1 (a), 13.2 (a)]
- (dd) The records shall be legible and updateable. [AS/ACIF S009:2006 Clauses 12.3.1 (b), 13.2 (a)]
- (ee) The records shall include details of any customer cabling connected to the MDF that runs outside the boundaries of the premises. [AS/ACIF S009:2006 Clauses 12.3.2, 13.2 (a)]
- (ff) Terminations and cross-connections used for any line providing power feeding exceeding 60 V d.c. or 42.4 V a.c. peak (30 V a.c. r.m.s.), but excluding a line that occasionally carries interrupted ring voltage (e.g. a standard telephone line), shall be clearly identified in the records and by appropriate labelling or marking of the MDF connection modules. [AS/ACIF S009:2006 Clauses 12.3.3, 13.2 (a)]

## Telstra requirements for customer MDFs

### General

Telstra’s requirements for customer MDFs are summarised below. These are to ensure that:

- the MDF can be safely accessed by Telstra workers;
- the customer’s safety is not unduly put at risk;
- the safety and integrity of Telstra’s network and services can be reasonably assured; and
- the length of cabling to the network boundary in the building is minimised.

## Location

- (1) The MDF should be located in a common service area within 20 metres radial distance of the Telstra building entry point, subject to the following additional considerations:
  - The MDF should be installed above known flood levels.
  - The MDF should be co-located with the building electrical switchboard to meet bonding/earthing requirements, as long as there is no earth potential rise (EPR) hazard.
  - The MDF should not be installed in an HV electrical switch room or near an HV transformer.

[Refer to page 8 of this document]
- (2) The MDF must **NOT** be located in an individual tenancy in multi-tenant premises unless the MDF is solely for the use of that tenant.

[Refer to page 8 of this document]

## Cable entrance facilities

- (3) The developer, builder, owner or customer is required to provide, or arrange and pay for, the building penetration and suitable tray, duct or conduit to support the Telstra lead-in cabling from the building entry point to the MDF. Facilities shared with other services are acceptable subject to the appropriate separations being maintained.

[Refer to page 12 of this document]

## Cable termination modules and backmounts

- (4) Telstra's standard terminating system for customer premises is the ADC KRONE Series 2 Disconnection Module, Profil. The MDF must include sufficient module backmounts on the Telstra side of the MDF to enable Telstra to fit the ADC KRONE modules and connect the Telstra lead-in cable at the MDF. Telstra will not connect its lead-in cables to any other terminating system under any circumstances.

[Refer to pages 13 and 17 of this document]
- (5) The backmounts used for the ADC KRONE modules may be either the Profil or turret style.

[Refer to pages 17 and 18 of this document]
- (6) Telstra services must be connected to the customer cabling by means of jumpers. Telstra will not:
  - connect its lead-in cables to any modules that are hard-wired or pre-jumpered to other connection modules or customer cabling; or
  - connect its lead-in cables to any patch panel or to any termination module that is hard-wired to a patch panel.

[Refer to page 18 of this document]

## Marking

- (7) The customer side of the MDF should be marked in the same way as the Telstra side, e.g. if the existing Telstra-side terminations are numbered from the bottom up, then the customer-side terminations should be numbered from the bottom up.

## Jumpers

- (8) No more than one (1) jumper may be connected to any pair of terminals on Telstra's side of the MDF.

[Refer to page 21 of this document]

# Customer MDF installation and usage guidelines

## MDF location

### General

While the MDF may be located either internally or on an external wall of the building, it should be installed inside the building for reasons of economy, reliability and security. Where the MDF is located externally, it must be installed in a suitable enclosure to protect it from the weather, access by children or unauthorised persons, and physical damage (e.g. vandalism). External MDFs are commonly locked by the owner or customer. In such cases, if it is not obvious where a key can be obtained to access the MDF, this should be indicated by a durable notice on or beside the MDF.

The MDF should be located in a common service area within 20 metres radial distance of the Telstra building entry point subject to the following additional considerations:

- The MDF should be installed above known flood levels.
- The MDF should be co-located with the building LV electrical switchboard to meet bonding/earthing requirements, as long as it will not be near any HV electrical equipment and there is no earth potential rise (EPR) hazard.

More information is provided below.

### Proximity to HV electrical equipment

The MDF should **NOT** be installed in an HV electrical switch room or within 15 metres of any HV transformer, whether either the MDF or the HV transformer is internal or external to the building.

### Proximity to the LV electrical switchboard

Whether the MDF is located internally or externally, it should be installed within a few metres of the LV electrical switchboard to minimise the equipotential bonding conductor length for connection of lightning surge suppression (see pages 24 and 25).

### Multi-tenant premises

In multi-tenant premises, the customer MDF should be located in a common service area of the same building in which the telecommunications services are to be used.

The MDF must **NOT** be located in an individual tenancy in multi-tenant premises unless the MDF is provided solely for the use of that tenant.

Notes:

1. Apart from security and privacy concerns, the installation of a common MDF in an individual tenancy may create access problems for Telstra and other service providers, and may cause inconvenience to that tenant and to the other tenants who rely on that tenant's goodwill for connection and repair of their telecommunications services.
2. Telstra may refuse to connect a telecommunications service to any MDF that is located in a tenancy other than that of the customer being supplied with the service.

### Freestanding MDFs

A so-called "MDF" that is not located in or on the customer's building (e.g. freestanding on land or attached to a fence, pole or other detached structure) is not a valid network boundary point in accordance with section 22 (4)(a)(i) of the Telecommunications Act 1997. The MDF must be installed in (or on) the customer's building. Telstra does not support the installation of such "MDFs" and may refuse to connect its lead-in cabling or any telecommunications services to such a device.

### Earth Potential Rise (EPR) hazards

For safety reasons, an MDF must **NOT** be installed within an EPR hazard zone. The cabling provider must survey the premises for the presence of power poles, towers, transformers and substations (i.e. located in the street, within the customer's premises or within adjoining premises) to ensure that the MDF will not be installed within an EPR hazard zone.

As a general rule, the MDF should not be installed:

- within **40 metres** radial distance of the base of a steel lattice tower or metal or concrete pole supporting HV power lines of 220 kV or higher
- within **16 metres** radial distance of the base of a steel lattice tower, metal or concrete pole, or a wooden pole with a down-conductor to an earth electrode, supporting HV power lines of 66 kV or 132 kV
- within **15 metres** radial distance of:
  - ⇒ a pole supporting HV power lines less than 66 kV and with any connections to underground power cable
  - ⇒ a pole supporting an HV power transformer
  - ⇒ a metal or concrete pole, or a wooden pole with a down-conductor to an earth electrode, supporting HV power lines less than 66 kV
  - ⇒ a wooden pole supporting HV power lines with a pole-top switch and either an all-metal down-rod or an earthing conductor extending up the pole above the handle
  - ⇒ a pad-mounted (ground level) HV power transformer
- within the minimum distance of a power generating station or a power distribution substation specified by the relevant power utility.

Refer to Appendix H of Australian Standard AS/ACIF S009:2006 (ACMA Wiring Rules) or Australian Standard AS 3835.1:2006 for more information.

Where the entire building is within an EPR hazard zone (e.g. a power generating station or a power distribution substation), the lead-in cabling may need special isolation equipment to be fitted at the building entry point or telecommunications services may need to be supplied by means of optical fibre or wireless technology. In such cases, the cabling provider must liaise with Telstra, through the relevant power utility, for safe connection of telecommunications services.

### General safety hazards

Notwithstanding anything contained in this document or any other document, the MDF must not be installed in any location or in such a way that may put the health or safety of any person required to work on the MDF at risk. For example, an MDF should not be located in a vehicle driveway or vehicle parking area without the provision of suitable barriers to protect a person working on the MDF from being struck by a moving vehicle.

### Access clearances

Suitable access clearances are required around the customer MDF to provide safe and convenient access to carriers, service providers and cabling providers. The access space is necessary to provide a person with sufficient head and shoulder room to terminate cables, test services and make cross-connections on the MDF. The area above, below and beside the MDF should not contain any protruding obstacles that may require any person to stoop or twist their body in order to gain access to cables or terminations within the MDF.

Where any MDF termination is installed at a height that requires the use of a ladder (this is only permissible for a floor-mounted or "island" MDF), additional clearance may be required around the MDF to allow positioning and climbing of the ladder safely and/or safe passage around the ladder.

Figures 2 to 5 illustrate minimum and maximum heights and clearances recommended to ensure that the installation complies with the mandatory requirements of AS/ACIF S009 and to ensure safe and convenient access.

### Surge suppressor clearance

A minimum clearance of 30 mm is required between the front face of the Telstra termination modules and the inside face of the front cover or door of the MDF enclosure in the fully closed position. This clearance is to provide for fitting of gas arrestor magazines. See Figure 6.

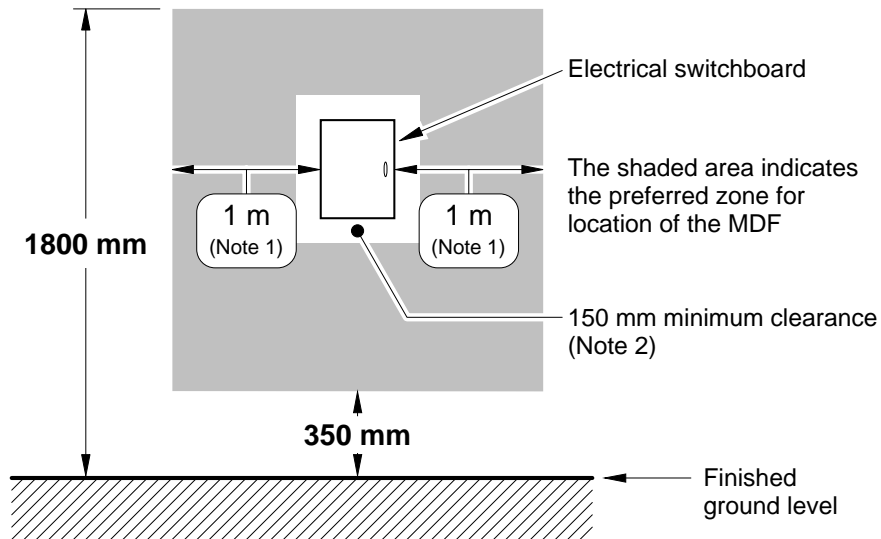

Notes:

1. It is recommended that the MDF be installed within 1 m of the electrical switchboard for ready location, access and to enable effective surge suppression to be provided. Care needs to be taken to avoid building fixtures such as downpipes, water pipes/taps, etc. and fences that adjoin the building.
2. The 150 mm clearance is an operational clearance (e.g. to allow for opening of the door/cover of the MDF or future expansion), and is not a safety requirement.

Figure 2 Installation zone for a wall mounted MDF on the external wall of a building [Figure D.1 of AS/ACIF S009:2006]

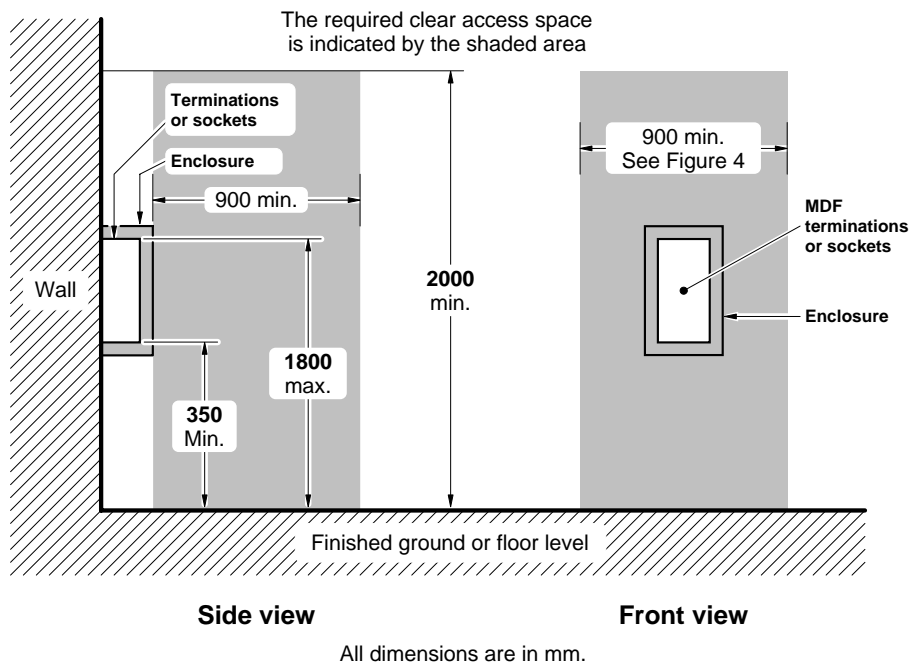
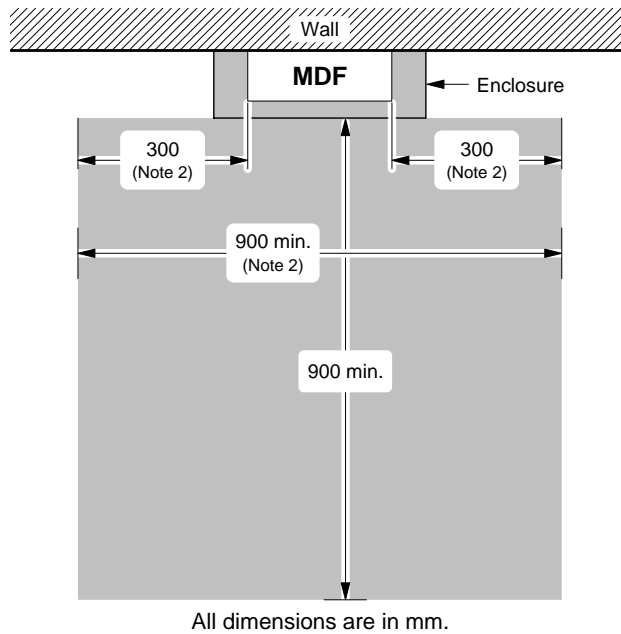

Figure 3 Access clearances for a wall mounted MDF [Figure D.2 of AS/ACIF S009:2006]



**Plan view**

Notes:

1. The shaded area indicates the space that should be kept clear of obstacles.
2. The 300 mm side clearance provides “shoulder room” for working on the MDF. The minimum required total clearance width in front of the device is 900 mm.

**Figure 4 Access clearances for a wall mounted MDF**  
[Figure D.3 of AS/ACIF S009:2006]

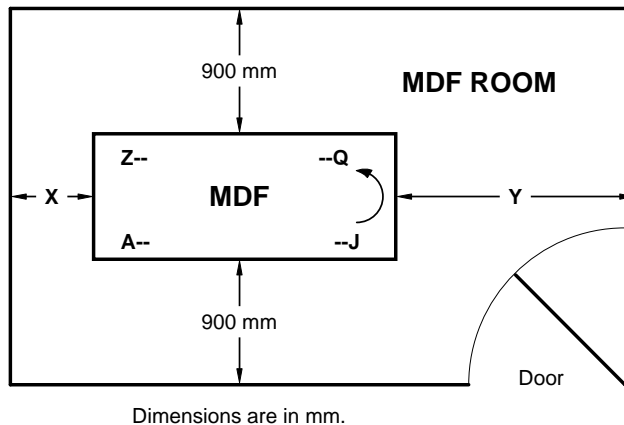

Notes:

1. Position the MDF within the room to obtain the required minimum clearances around it.
2. The fixed end clearance, marked “X”, must be sufficient to provide “shoulder room” for working on the MDF, i.e. a minimum of 300 mm. However, sufficient clearance should be provided to enable ready escape from the vicinity under emergency conditions — a minimum distance of 600 mm is recommended for this purpose. If the MDF has cable terminations facing the end wall, a minimum distance of 900 mm is required.
3. The end clearance marked “Y” should be sufficient to provide for MDF expansion, access and ready escape from the vicinity under emergency conditions — a minimum distance of 1200 mm is recommended.
4. A minimum frontal clearance of 900 mm working space from the vertical face of the termination side of the MDF and a minimum vertical clearance of 2 m from the walked-on surface are required.
5. The MDF verticals must be designated alphabetically from left to right (i.e. in an anti-clockwise direction) as shown. A gap should be provided in the vertical designations as indicated above (e.g. K-P) to allow for verticals to be added later without the need to redesignate the existing verticals.

**Figure 5 Access clearances for a floor mounted or “island” MDF**

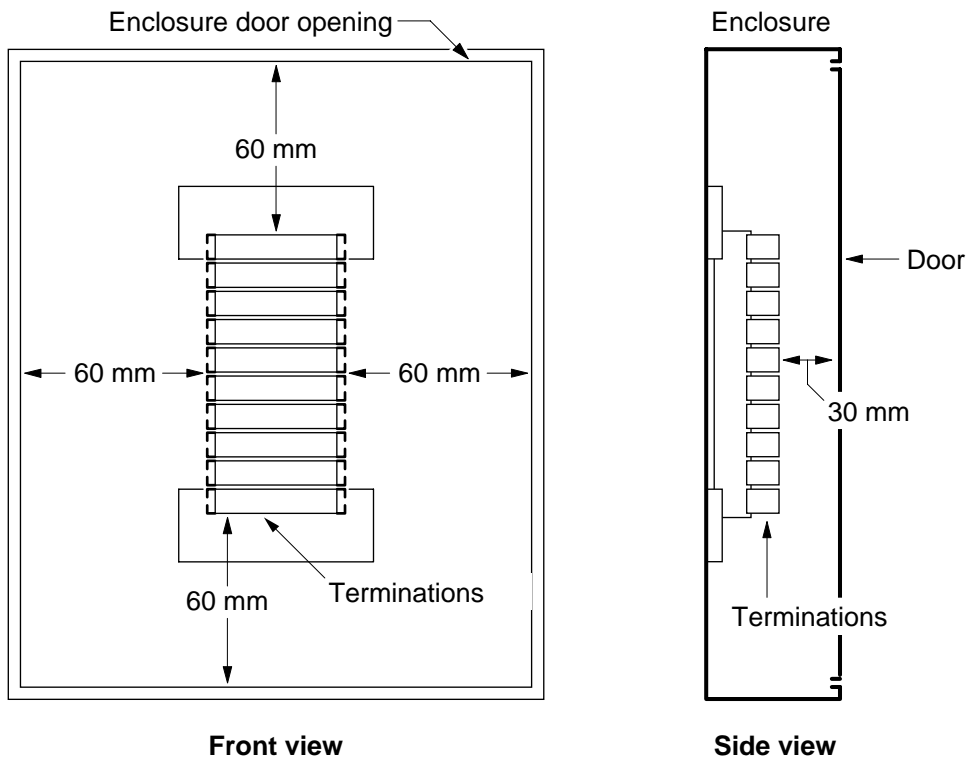

## Notes:

1. A minimum clearance of 30 mm is required in front of the Telstra modules to allow for fitting of surge suppression devices (this is an ACMA requirement).
2. Sufficient clearance is required around the termination modules to connect cables and run jumpers. While the ACMA wiring rules do not specify access clearances for this purpose, a minimum clearance of 60 mm is recommended between the modules and the sides of the MDF enclosure to provide "finger access" to the jumpers at the sides of the modules.

Figure 6 Clearances within an MDF enclosure

## Cabling between the building entry point and the MDF

For internal MDFs, the building owner should provide suitable lead-in cable entry facilities and a suitable pathway for running the lead-in cable between the "building entry point" (cable entry point) and the MDF. Facilities such as cable trays or trunking shared with other services are acceptable subject to the appropriate separations being maintained.

Note: The internal lead-in cabling must be separated from other services in accordance with sections 8, 9 and 16 of the ACMA wiring rules (AS/ACIF S009:2006), which may be freely downloaded from [www.commsalliance.com.au](http://www.commsalliance.com.au).

## Home or small office networking distributor

For a new individual home (single dwelling or individual ground-level home unit) or small business having similar characteristics, if a networking distributor (patch panel) is to be installed, the Telstra lead-in cable must be connected to a Telstra NTD at the building entry point with tie cables between the NTD and the home/office networking distributor in accordance with Australian Standard AS/NZS ISO/IEC 15018, "Information technology — Generic cabling for homes" and Standards Australia Handbook HB 252, "Communications Cabling Manual Module 3: Residential communications cabling handbook". This principle is illustrated in Figure 7 (a).

Note: Registered cabling providers are authorised to install the NTD under the terms and conditions of Telstra Specification 012882, "Alteration of Telstra Facilities in Homes and Small Businesses — Information for Cabling Providers" (otherwise known as "A2A" — "Authorisation to Alter") and Specification 012688, "Telstra Network Termination Device — Information for Cabling Providers". These specifications may be accessed on the Telstra Smart Community® web site [www.telstra.com.au/smartcommunity/](http://www.telstra.com.au/smartcommunity/) (look under "Builders").

Where home/office networking is to be installed in an existing building and it is impractical to retrofit a Telstra NTD, the patch panel must be cabled from the first telecommunications outlet (TO), which may be relocated to a point next to, but not in or on, the patch panel, in accordance with Telstra Specification 012882. Alternatively, the lead-in cable may be connected to a separate ACMA-compliant and Telstra-compliant customer MDF from which tie cables may be run to the patch panel. This principle is illustrated in Figure 7 (b).

Note: Telstra lead-in cabling must be connected on any customer MDF by Telstra. Non-Telstra cabling providers are not authorised to do this. However, the MDF itself is installed by the cabling provider.

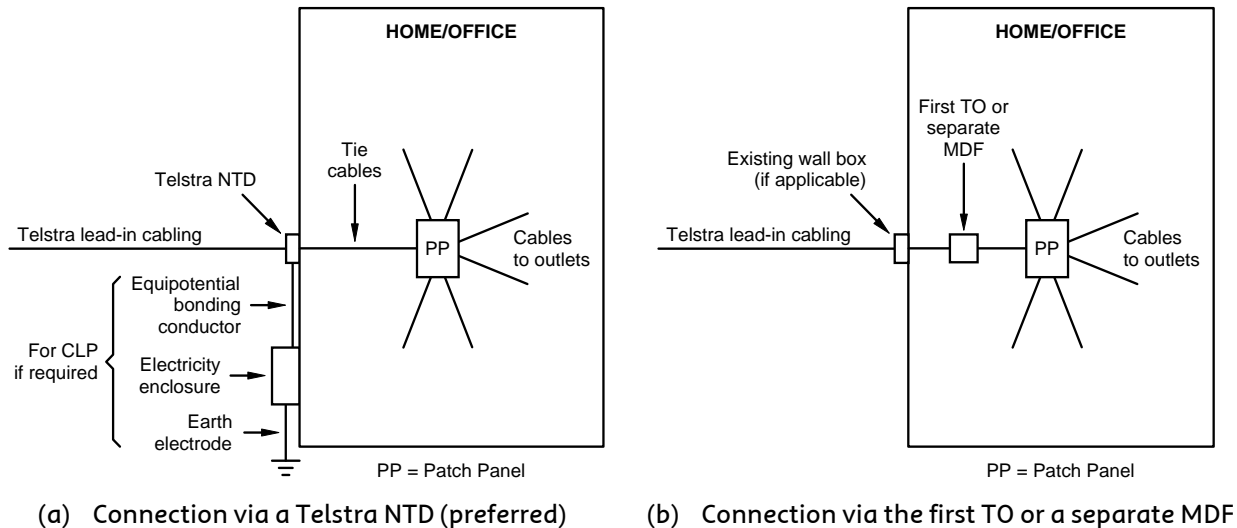

Notes:

1. The patch panel (PP) enables end-users to change service and telecommunications outlet (TO) connections to meet their particular requirements. The patch panel should be connected via a Telstra NTD, as shown in (a), which is in accord with Australian Standard AS/NZS ISO/IEC 15018 and Standards Australia Handbook HB 252. Alternatively, the patch panel may be connected via the “first TO”, which may be relocated to a position near, but not in or on, the patch panel, or via a separate ACMA-compliant and Telstra-compliant customer MDF, as shown in (b).
2. Telstra lead-in cable shall **NOT** be connected directly to the patch panel unless it meets all ACMA and Telstra requirements for an MDF (see pages 4 to 7).

Figure 7 Connection of a home or small office networking distributor

## MDF design

There are numerous brands and styles of customer MDFs available. Smaller MDFs may be supplied as a complete unit whereas larger MDFs are usually assembled on site using ACMA-compliant components. In the latter case, products must be selected and used according to the relevant requirements of Australian Standards AS/ACIF S008 (“Requirements for customer cabling products”) and AS/ACIF S009 (wiring rules) for MDFs.

The cable terminating system used on the customer side (“B” side) of the MDF may be any ACMA-compliant type. However, the terminating system used on the carrier side (“A” side) of the MDF must be the carrier’s standard terminating system for customer MDFs (ADC KRONE Series 2 Profil-mount Disconnection Modules in Telstra’s case). Other carriers may use different terminating systems, so it is important to ascertain what terminating systems they use for customer MDFs.

Notes:

1. Telstra uses assorted cable terminating systems for various applications. For example, Telstra uses different terminating systems in exchange MDFs, roadside cabinets and pillars. However, only ADC KRONE Series 2 Disconnection Modules (Profil) may be used for terminating Telstra lead-in cables on customer MDFs.
2. While the installer of the customer MDF must ensure that the MDF is capable of terminating ADC KRONE Series 2 modules on the Telstra side of the MDF (e.g. by providing suitable backmounts), the termination modules themselves will be supplied and installed by Telstra.

Where the “B” side of the customer MDF is not ADC KRONE or ADC KRONE compatible, it may be necessary for the building owner, manager or customer, as applicable, to make suitable terminating tools and usage instructions available at the MDF for use by carriers and service providers or, alternatively, arrange for their own cabling provider to connect service jumpers to the “B” side of the MDF as and when required (see “Tagging of service pairs” on page 20).

### **Small MDFs**

The ADC KRONE 10-pair MDF illustrated in Figure 8 is a popular MDF for termination of lead-in cable up to 10 pairs and is an example of a style of MDF that uses vertically orientated termination modules.

With this particular MDF, the “A” side termination module is supplied with it (the module is moulded into the base). The MDF has limited capacity for termination of customer (“B” side) cables, and its use should be limited to simple network interfacing applications, such as shown in Figure 7 (b), or for cases where no more than 8 to 10 customer cable pairs are ever likely to be terminated. Figure 8 shows how cables and jumpers are terminated on this MDF.

Other types of MDF that use the same vertical module mounting arrangement (e.g. Madison Model 30 MDF) are similarly terminated.

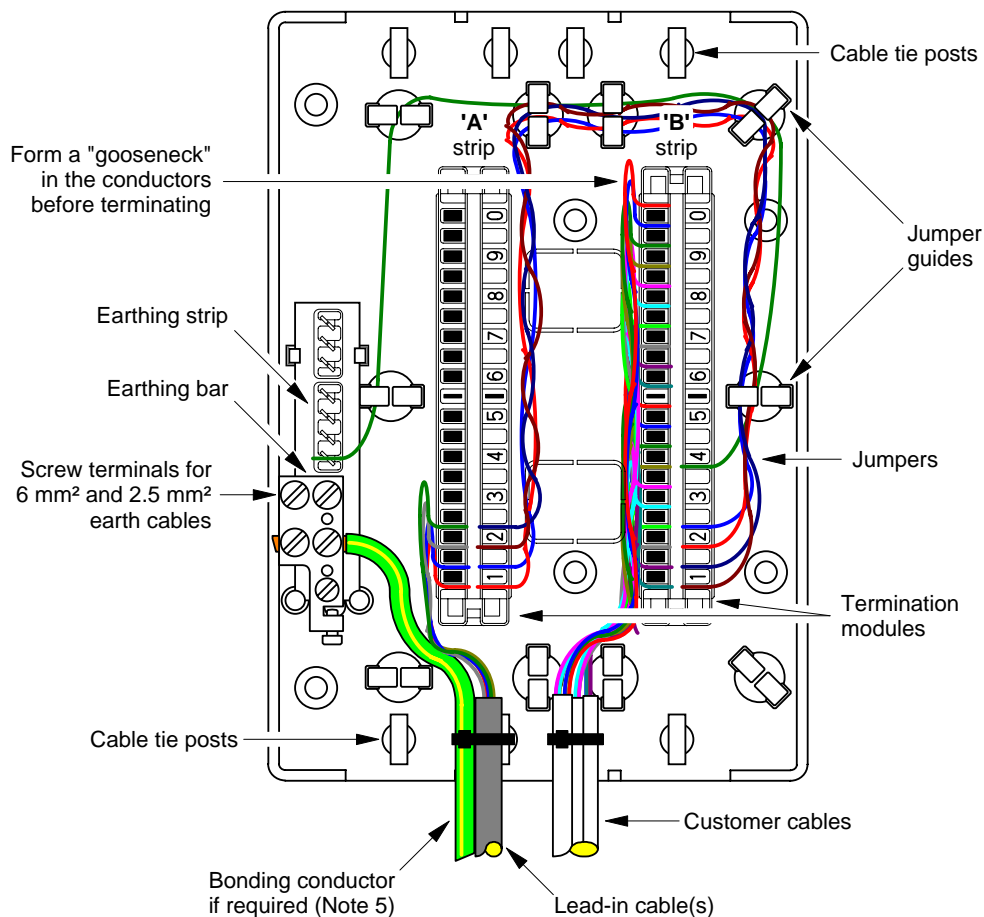

## Notes:

1. This particular MDF is for internal (indoor) use only but may be used outdoors if housed in a suitable weather resistant enclosure. It has a deep cover to accommodate an ADC KRONE arrester magazine. The 10-pair ADC KRONE MDF should not be confused with the ADC KRONE 20-pair Final Distribution Point, which looks similar but has a shallow cover and no metal strap between the earth bar and the "A" side module for an arrester magazine. The 20-pair FDP must **NOT** be used as an MDF.
2. The "A" strip is reserved for carrier cables. The "B" strip is used for connection of customer cables. This MDF has no room for expansion and should only be used where no more than 8 to 10 customer cable pairs are ever likely to be terminated.
3. Terminate cables on the left (unnumbered) side of the module, and connect jumpers on the right (numbered) side of the module, as shown above. Leave a "gooseneck" in the cable conductors to allow for disconnection and re-termination of conductors for testing purposes. Leave sufficient slack in jumpers to enable them to be traced.
4. An ADC KRONE terminating tool must be used for terminating cables on this MDF. Other brands of tool must **NOT** be used. Use of a non ADC KRONE tool may damage the modules.
5. The MDF should be equipotentially bonded to the electrical earthing system in accordance with Australian Standard AS/ACIF S009:2006 (wiring rules) to facilitate the installation of effective surge suppression for the protection of the end-users of the telecommunications services. See page 24 for more information.

Figure 8 10-pair ADC KRONE MDF

MDFs are available as frame assemblies on which the required number of termination modules may be mounted. These are available for indoor or outdoor use. Some MDFs used for termination of lead-in cables of 10 to 50 pairs may only contain one backmount or "vertical" for mounting of both "A" side and "B" side termination modules. In such cases, the demarcation between the "A" side and the "B" side of the MDF may be less obvious than with larger MDFs that have several verticals.

A typical single vertical MDF is illustrated in Figure 9.

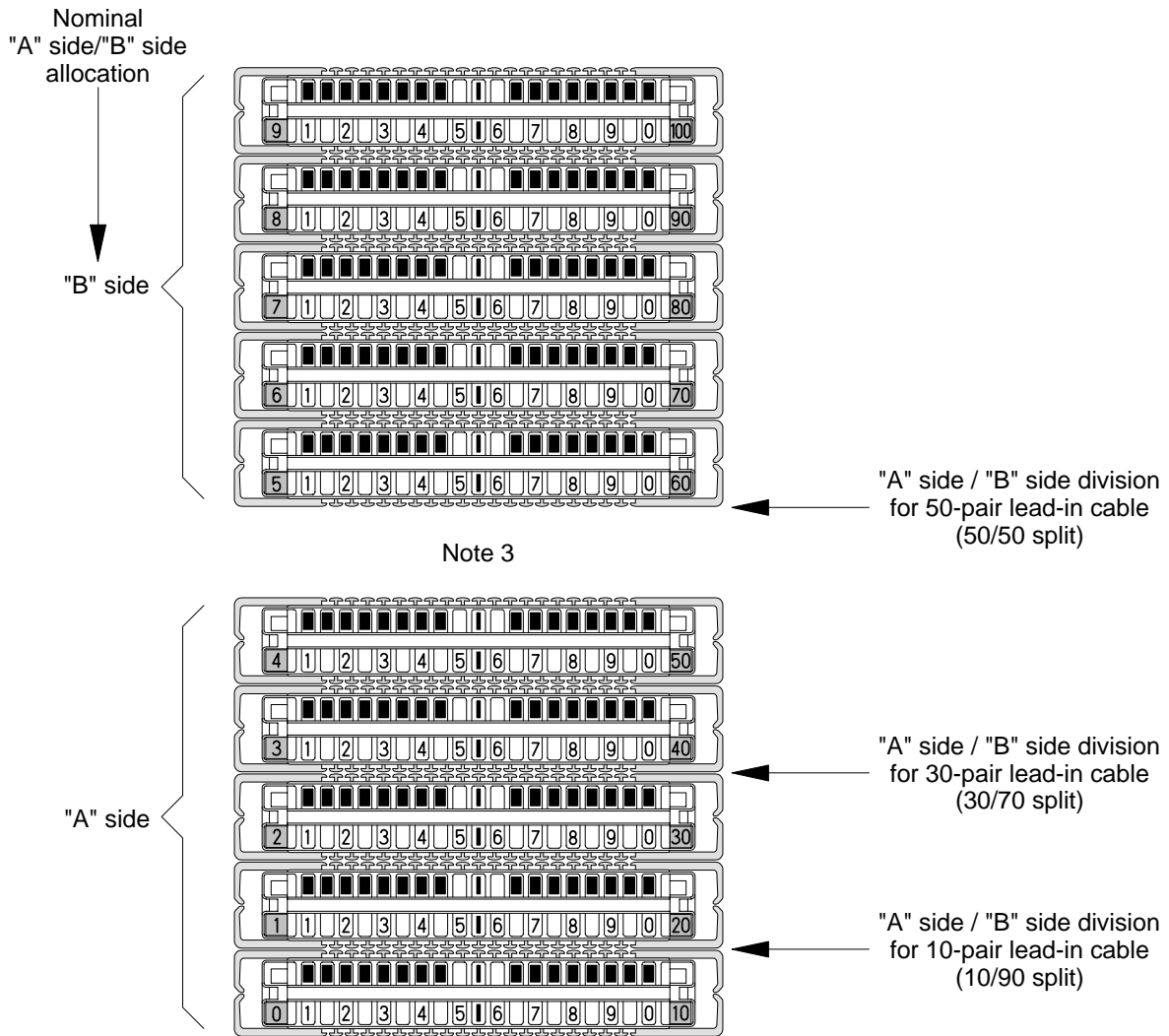

Notes:

1. The "A" side of the MDF comprises the termination modules or backmounts allocated for termination of carrier cables. The "B" side of the MDF comprises the modules allocated for connection of customer cables.
2. The "B" side modules, earthing conductors and the MDF itself (backmount, enclosure, etc.) are supplied and installed by the cabling provider. The "B" side modules may be any ACMA-compliant type. The "A" side modules are supplied, installed and owned by the carrier (e.g. Telstra). Telstra modules will be ADC KRONE Series 2 Disconnection Module, Profil. Customer cables must **NOT** be terminated on these modules even if they have spare capacity.
3. A vacant module position should be left between the "A" side and "B" side modules for physical demarcation between the two sides. Alternatively, use this module position for mounting of a label or test module.

Figure 9 Typical "A" side and "B" side allocations for an MDF with a single "vertical"

Bay frame MDFs and MDF racks

Larger wall mounted ("bay frame") or freestanding ("rack mounted") MDFs have two or more verticals for termination of carrier cables and customer cables. The lead-in cables generally terminate on separate verticals to the customer cables. While the carrier side of the MDF is often referred to as the "A" side of the MDF, lead-in cables do not actually have to be terminated on the "A" vertical. Verticals allocated for termination of lead-in cables may be any suitable vertical within the MDF. It is not uncommon for lead-in cables to terminate on a vertical in the middle or on the

right side of the MDF or to be spread among a number of verticals (e.g. where lead-in cables are added some time after the initial MDF installation).

Fitting and termination of lead-in termination modules on larger MDFs are the same as for smaller MDFs (see page 18).

For information about obsolete solder-tag MDFs, see page 29.

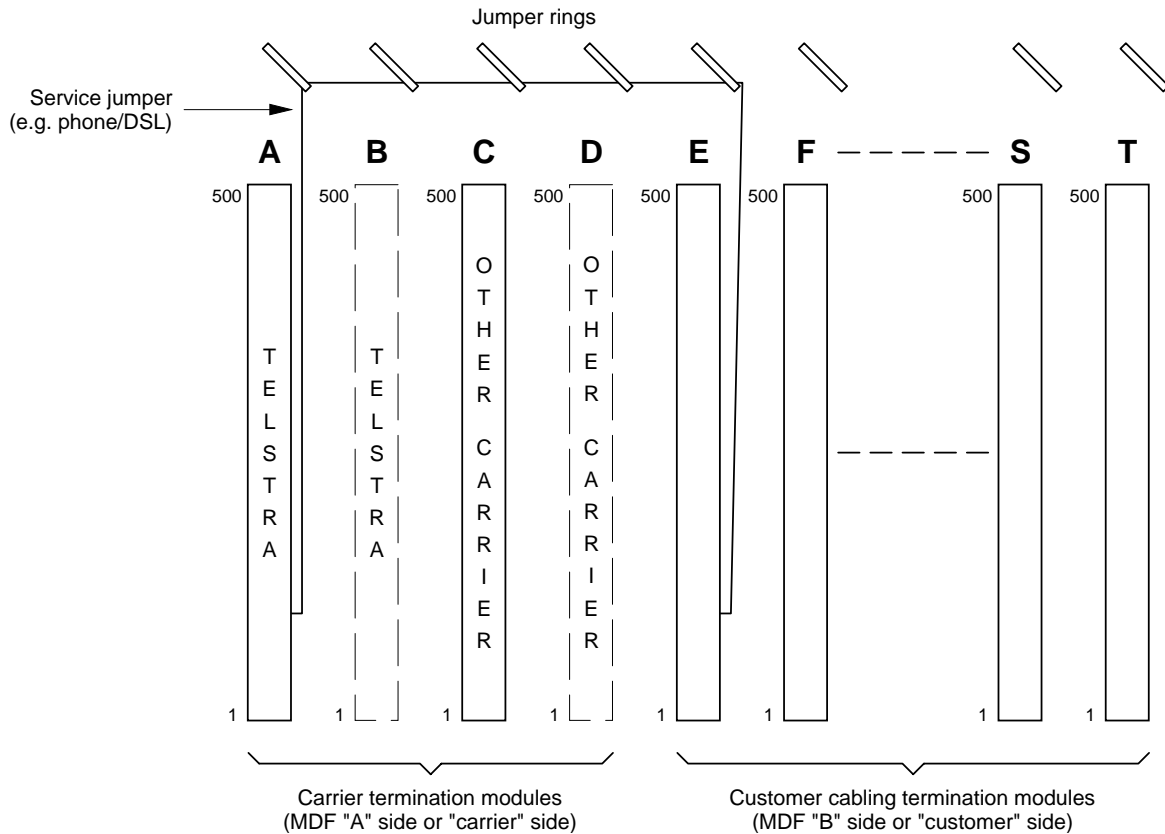

#### Notes:

1. While it is preferred that the network terminations be at the left-hand end of the MDF, this is not always achievable and by no means essential. Nevertheless, verticals should be selected, where possible, such that all of a particular carrier's verticals/modules are adjacent whether or not they also happen to be adjacent to the other carrier's verticals/modules.
2. In the above example, verticals A + B and C + D would be set aside for Telstra and other carriers' lead-in cables and termination of each carrier's network equipment.

Figure 10 Typical bay frame MDF layout

## Cable termination modules

It is an ACMA requirement for the MDF to be capable of accommodating the carrier's standard cable termination modules on the "A" side so that the carrier can install these modules in the MDF and terminate the lead-in cable on them. Telstra's standard cable termination module for use on customer MDFs is as follows:

ADC KRONE Series 2 Disconnection Module (1-0), Profil Mount, 10-pair,  
Telstra serial/item 537/171, ADC KRONE Product No. 6468 5 043-10 (Box of 10)

This module will mount on either a Profil (rod) or turret (notched) style ADC KRONE backmount (see page 18) and will terminate 0.40 mm to 0.64 mm diameter solid copper conductors. It is not suitable for terminating 0.90 mm diameter conductors.

Telstra will **NOT** agree to terminate its lead-in cable on any other type of connection module.

The installer of the MDF should ensure that sufficient backmounts are provided for Telstra to be able to terminate all lead-in cable pairs. Additional capacity of at least 50% should also be provided for future expansion.

The connection modules for termination of Telstra's lead-in cable will be supplied and installed on the backmounts, and the lead-in cable terminated on the modules, by Telstra.

Non-Telstra cabling providers must **NOT** terminate Telstra lead-in cable on any MDF unless authorised in writing by a Telstra person with the authority to do so for that specific MDF.

### ADC KRONE backmounts

Two styles of ADC KRONE backmount may be used for mounting the Telstra termination modules:

- rod ("Profil") type, as shown in figure 17; or
- turret (notched) type, as shown in Figure 18.

Telstra does not have any preference for the style of backmount used — either type is suitable.

At least one type of small MDF, described on pages 14 and 15, includes both the "A" side and "B" side modules moulded into the base, such that none of the above backmounts is required.

### Cross-connections (jumpers)

Telstra services must be connected to the customer cabling by means of jumpers. Telstra will **NOT** connect its lead-in cabling to:

- any cable distribution device that does not use jumpers other than the Telstra NTD described in Telstra Specification 012688;
- any modules that are hard-wired or pre-jumpered en masse to other connection modules or customer cabling; or
- any patch panel or any MDF termination module that is hard-wired to a patch panel.

Note: Jumpers provide Telstra some control over connection of network services to customer cabling to prevent such things as accidental connection of power feed pairs to a customer's telecommunications outlet (prohibited by ACIF Code C559 Part 1) or accidental connection of a service intended for another customer or another address.

Service jumpers (i.e. jumpers from the "A" side to the "B" side of the MDF to connect a Telstra network service) are normally run by Telstra. However, Telstra may require the customer's service provider or cabling provider to run the jumper or to connect the "B" end of the jumper if:

- the "B" side pair has not been tagged or otherwise identified beforehand by the service provider or cabling provider; or
- the Telstra installer does not have a suitable terminating tool to connect the "B" end of the jumper on the "B" side termination modules, which may be a type that Telstra is not familiar with.

A non-Telstra cabling provider is permitted to run a service jumper to connect a new service if the "A" side pair has been tagged or otherwise identified in writing by Telstra for the specific purpose of authorising a cabling provider to connect a jumper to that pair (see page 20).

A non-Telstra cabling provider may make or alter any connection on the "B" side of the MDF.

A non-Telstra cabling provider may remove a "dead" jumper (e.g. to free up a pair on the "B" side of the MDF) if all reasonable steps have been taken to ensure that a working service is not accidentally disconnected (see page 22).

## Connection of cables and jumpers on ADC KRONE modules

The cabling provider shall terminate any jumper on a Telstra “A” side MDF module in accordance with the ADC KRONE Technical Manual, using either of the following tools:

- ADC KRONE “S” (Sensor) Connection Tool, ADC KRONE Product No. 6417 2 055-01; or
- ADC KRONE Connection Tool, ADC KRONE Product No. 6089 2 003-00.

No other brand of tool may be used for termination of jumpers on the Telstra (“A” side) modules.

Guidelines for termination of cables and jumpers on ADC KRONE modules are provided in Figures 11 and 12.

Telstra lead-in cables must be terminated by Telstra.

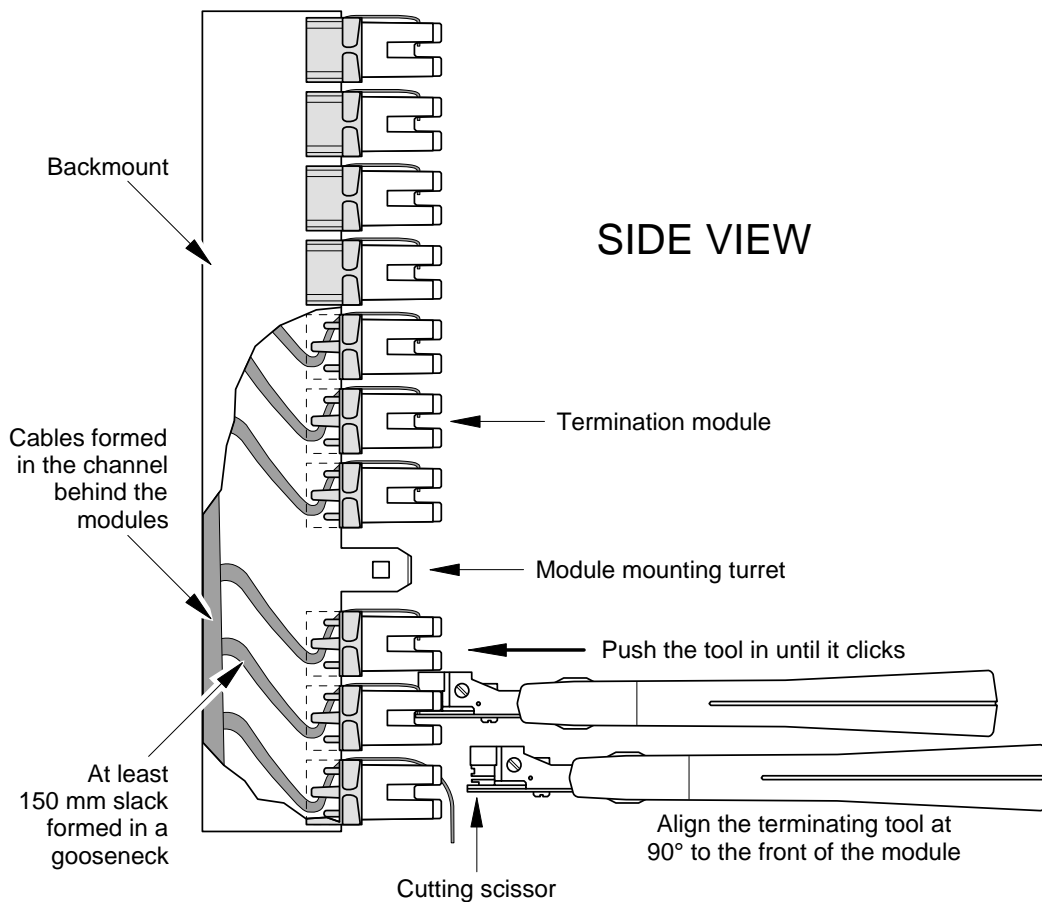

### Notes:

1. The ADC KRONE modules may be mounted on a turret style backmount (shown above) or a Profil (rod style) backmount (see Figure 17).
2. Remove the cable sheath about 30 mm to 50 mm into the frame unit or backmount. Tie the cable sheath lightly to the frame unit or backmount using a suitable cable tie.
3. Leave at least 150 mm slack in the cable pairs in a “gooseneck” behind each module so that the module can be removed or swung out (Profil) from the backmount for inspection, maintenance, or to gain access behind the modules to add cables. Lightly bind or tie the conductors into 10-pair tails for termination on each module.
4. An ADC KRONE terminating tool must be used for terminating cables or jumpers on ADC KRONE modules. Use of any other brand of tool may damage the modules.
5. Terminate cables from the bottom up, i.e. fan out and terminate the first 10 pairs on the bottom module, then fan out and terminate the second 10 pairs on the second module, and so on. Refer to Figure 12.

**Figure 11 Termination of cables or jumpers on ADC KRONE Series 2 modules**

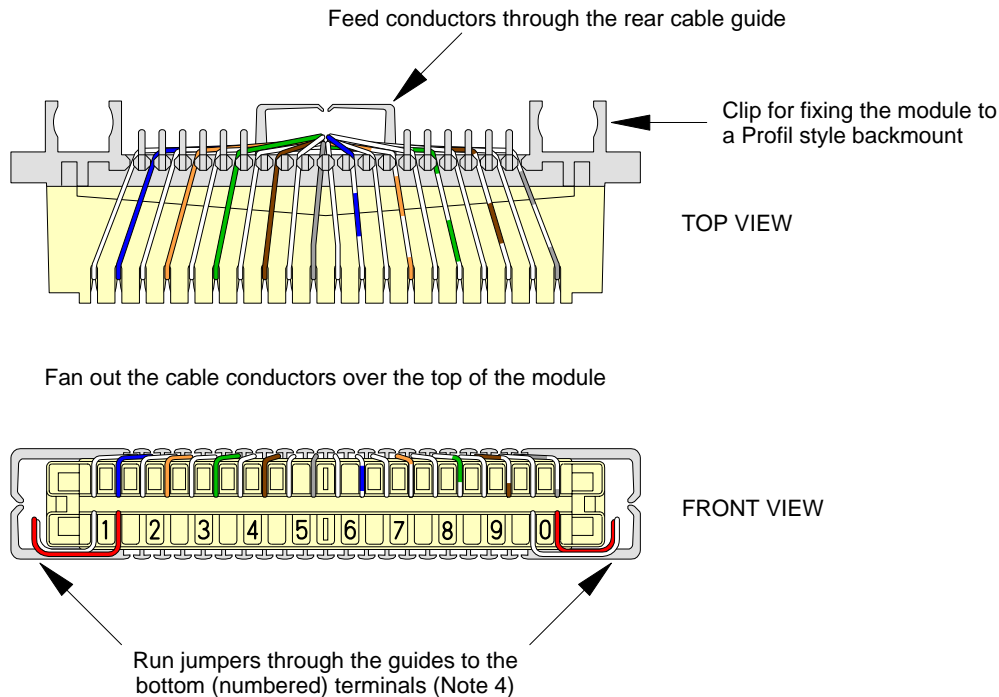

## Notes:

1. Fan out the cable conductors over the top of the module as shown. Lightly bind or tie the conductors together in 10-pair bundles, and leave at least 150 mm slack in a gooseneck behind the module.
2. To terminate the conductor:
  - Place the unstripped conductor in the slot.
  - Insert the terminating tool over the conductor (align the tool with the slot).
  - Push the tool in until an audible click is heard. This indicates that the conductor has been correctly cut and terminated.
3. An ADC KRONE terminating tool must be used for terminating cables and jumpers on ADC KRONE modules. Use of any other brand of tool may damage the modules.
4. Run jumpers through the jumper guides at the side of the module to the bottom (numbered) terminals. There is a jumper guide on each side of the module. With turret style backmounts, run jumpers for pairs 1-5 through the left hand guide, and run jumpers for pairs 6-10 through the right hand guide. However, for Profil (rod style) backmounts, all jumpers should be run through one guide only (either left or right) to enable the module to be swung (hinged) out.
5. Leave sufficient slack in jumpers (generally 50 mm to 100 mm) to enable them to be traced while still connected at both ends.

Figure 12 Termination of cables and jumpers on ADC KRONE Series 2 modules

## Tagging of service pairs

Telstra may tag a carrier side MDF pair for the purpose of authorising a cabling provider to connect a jumper to that pair. Alternatively, the tag may be secured to the end of a jumper that has been run to the customer side of the MDF for termination by the customer's service provider or cabling provider to the appropriate pair on the customer side of the MDF.

In the former case, the tag will be connected to the relevant pair by a short length of insulated jumper wire as illustrated in Figure 13. This jumper wire must be removed before the permanent jumper is connected to the pair. It is recommended that all jumpers on other distributors be run first and that the final connection is made on the carrier side of the MDF in case the jumper wire on the tag is intentionally short-circuiting the line for some reason.

The correct terminating tool must be used to terminate the jumper on either side of the MDF.

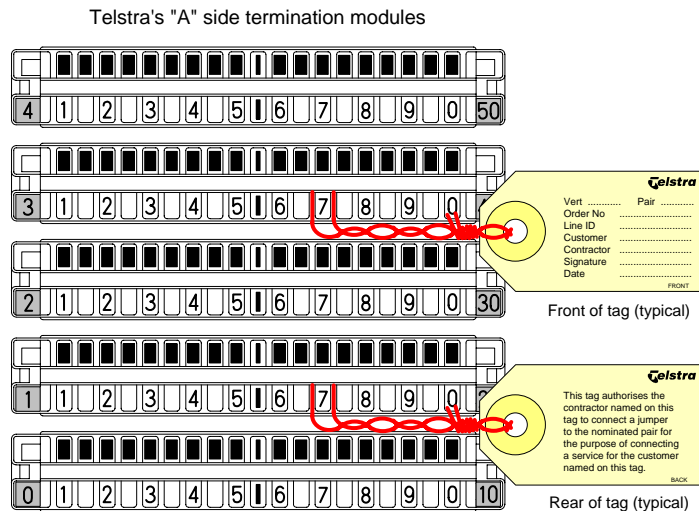

Notes:

1. Telstra may tag the service pair on the “A” side MDF for the purpose of authorising a cabling provider to connect a jumper to that pair. Alternatively, Telstra may secure the tag to the end of a jumper that has been run to the “B” side of the MDF for termination by the customer’s service provider or cabling provider on the appropriate “B” side pair.
2. The tag should contain sufficient information to ensure that the correct service will be connected to the correct customer.

Figure 13 Typical tagging of a Telstra service pair on the “A” side of a customer MDF

### Double jumpering

Telstra does not support connection of more than one jumper to any pair of terminals on its termination modules.

Where services are to be double-jumpered at the MDF, e.g. for parallel service appearances at different locations in the building (either permanently or temporarily while the customer is moving from one part of the building to another), the double connection must be made on the customer's side of the MDF as shown in Figure 14. Make the permanent jumper connection to the customer side first, then make the temporary connection over the top of the permanent jumper (assuming that double terminations are supported by the type of module used) so that the temporary jumper may be removed without disturbing the permanent jumper.

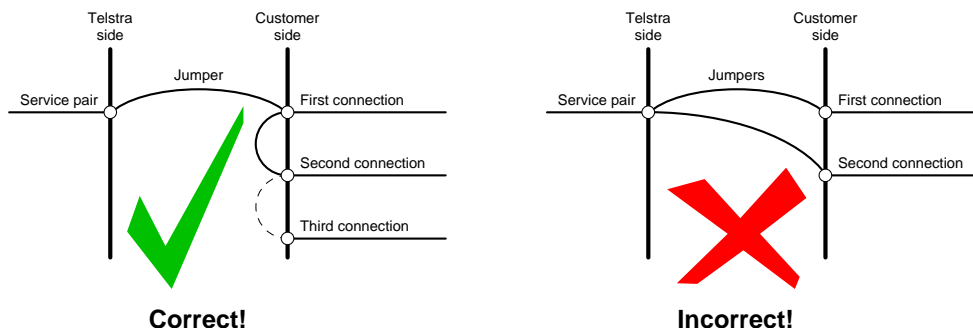

Notes:

1. Telstra does not support double-jumpering on its termination modules.
2. Where any service is to be double-jumpered, the double-connection must be made on the customer’s side of the MDF as shown at left. If more than two connections are required, the service should be double-jumpered from the second connection as indicated.

Figure 14 Double-jumpering of a service at the MDF

## Disconnection of dead jumpers

It is standard Telstra practice to leave jumpers for cancelled services in-situ within any MDF to provide the opportunity for the services to be taken up “in place” at a reduced connection charge by an incoming customer. Nevertheless, not all cancelled services are taken up “in place”, and eventually old jumpers for cancelled services (called “dead” jumpers) may accumulate to a stage where they clutter up the MDF and tie up spare pairs in the cables connected on the customer side of the MDF. It then becomes necessary to identify and remove dead jumpers to free up pairs in the customer cabling.

A cabling provider may remove dead jumpers from the carrier and customer sides of the MDF as long as all reasonable steps have been taken to ensure that a working service is not inadvertently disconnected. Note, however, that cabling providers are not permitted to remove or alter permanent cabling on the carrier’s side of the MDF, e.g. lead-in cable. The following guidelines have been developed to assist cabling providers in identifying and removing dead jumpers.

### Identifying dead jumpers

In identifying and removing dead jumpers, the cabling provider should not rely solely upon the MDF records or other distributor records to identify or determine the status of a service or jumper. Service identification, and the termination points of each service, should be determined by physically tracing jumpers and distribution cable pairs back to the MDF from the customer end, i.e. starting from the floor distributor or last distributor, as applicable.

Due to the high risk of disrupting important circuits, the status of a jumper, i.e. whether it is working or dead, should not be checked by means of a low impedance test device, e.g. buttinski, without first taking steps to determine with a good degree of confidence that it is not a data circuit or a physical bearer for line multiplexing equipment. Even then the test may be inconclusive in many cases due to the incidence of physical working pairs which may not exhibit the obvious signs of an active pair, i.e. some working pairs have no dial tone or measurable voltage across the pair. Examples are:

- incoming telephone lines (as distinct from bothway or outgoing lines)
- some unconditioned local loop (ULL) services
- naked DSL services (these may be supplied via ULL)
- 4-wire cailho lines (e.g. amplified circuits, E&M tie lines, 2048 kbit/s digital bearers)
- some “private” lines (e.g. used as virtual circuits)
- switched circuits (i.e. circuits which are only active when switched through from the carrier’s telephone exchange or customer equipment at the premises).

A method for checking existing jumpers and records is as follows:

- (a) The on-site records for the customer’s last cable distribution point (e.g. floor distributor) should be consulted, and cable terminations and termination hardware should be checked for consistency with the cable records. If this physical check is positive, those services recorded as telephone services may be verified with a buttinski or a voltmeter, as appropriate.

Notes:

1. Some circuits, such as incoming lines or indial trunks, will not provide dial tone when looped.
2. Incoming lines may not exhibit a voltage across the line pair unless an incoming call is in progress.
3. Indial trunks will not usually exhibit a voltage across the line pair unless connected to an indial circuit at the PABX, i.e. the line voltage originates from the PABX, not the public telephone exchange.
4. Services recorded as non-telephone, e.g. ULL, DSL, data, teleprinter, telemetry, private line or bearer circuits, must not be checked by use of a low impedance test device such as buttinski or analogue multimeter. Such services should be physically traced, as far as is practicable, to the equipment to verify the correctness of the records. The records must be verified to the carrier side of the MDF by the above process, including physical tracing of the jumpers where necessary.
5. Where the cable records are missing or suspect, new records should be reconstructed to the extent necessary by physical tracing of cables and jumpers.

- (b) Services/pairs should be physically traced back towards the MDF through all intermediate distribution points, where applicable. This may be achieved by checking of cable records against the termination hardware and physical tracing of jumpers from the “B” side to the “A” side of each distributor starting at the distributor closest to the customer.

Note: It should not be necessary to re-test working pairs with a buttinski or similar device at intermediate distribution points unless the records are suspect.

- (c) The above process should be repeated at the MDF.
- (d) If the MDF records are missing or not consistent with the actual plant, new records should be constructed by physical tracing of cables and jumpers. Where necessary, Telstra may agree to supply replacement “A” side MDF records using Telstra’s external plant records, at appropriate charges.

## MDF records

The MDF records are supplied by the installer of the MDF. The maintenance and safekeeping of these records are the responsibility of the building owner, manager or customer, as applicable. The MDF records may be stored electronically and/or maintained off site. However, in such cases there should be a hard copy of the records available at the MDF and/or a notice at the MDF indicating where or how the records can be accessed.

Telstra will enter lead-in cable details in the MDF cable records when the lead-in is terminated on the MDF, if the records are available. The details normally include the number of pairs (e.g. “100 pair lead-in cable”) and the corresponding “O” side or “main” side pair designations. The lead-in cable details may be entered in either permanent (waterproof) ink or in pencil.

Telstra will also enter service and cross-connection (jumper) details in the MDF cable records, if available, as and when each service is connected on-site by Telstra. If Telstra authorises a cabling provider to do the service cross-connection (e.g. by tagging the “A” side of the MDF as described on page 20), Telstra will rely on that cabling provider to enter the cross-connection details in the cable records — however, the service details will be entered on the “A” side records by Telstra, where appropriate (see Notes).

Notes:

1. Telstra will not make a special visit to the premises to enter or adjust MDF records if a customer takes up an in-place service or cancels a service.
2. Unlisted numbers or non-essential information should not be entered in the cable records by either Telstra or the cabling provider.

Medium to soft lead pencil should be used to enter service identification and cross-connection details, i.e. HB, B or 2B. Hard pencil such as H, 2H or 4H must **NOT** be used.

TELECOMMUNICATIONS CABLING RECORD						
Location <i>MDF</i>		Floor <i>B</i>	Distributor No. <i>BA</i>	Vertical <i>D</i>		
CABLE ORIGIN		TERMINATION PAIR NUMBER	SERVICE DETAILS (e.g. Telephone number or extension port for telephone services)	JUMPER TO		OTHER DETAILS (e.g. user name or workstation location)
DISTRIBUTOR ID	VERTICAL PAIR			VERTICAL FRAME	PAIR	
↑ 25 PAIR CABLE TO DISTRIBUTOR 1A IN RISER LEVEL 1 VERTICAL A PAIRS 1-25	A 25	D 50				
		9	388750	A	2	ADSL
		8				
		7	388831	A	16	ADSL
		6				
		5	388146	A	11	
		4				
		3	387712	A	23	FAX
		2				
		1	387645	A	3	
↓ 25 PAIR CABLE TO DISTRIBUTOR 1A IN RISER LEVEL 1 VERTICAL A PAIRS 1-25		D 40				
		9		A	5	ADSL
		8				
		7	38812	A	29	
		6				
		5	389823		12	FAX
		4	389822		18	FAX
		3				
		2				
		1				
↓ 25 PAIR CABLE TO DISTRIBUTOR 1A IN RISER LEVEL 1 VERTICAL A PAIRS 1-25		D 30		A	1	
		9	389191	A	7	
		8	UNLISTED NO.	A	30	
		7	387132	A	25	
		6	387233	A	13	
↓ 25 PAIR CABLE TO DISTRIBUTOR 1A IN RISER LEVEL 1 VERTICAL A PAIRS 1-25	A 1		388011	A		
	A 25					
↑ 25 PAIR CABLE TO DISTRIBUTOR 1A IN RISER LEVEL 1 VERTICAL A PAIRS 1-25		D 20				
		9				
		8				
		7				
		6				

Note: Details of the permanent cabling may be entered in the MDF record book in permanent (waterproof) ink or in pencil. However, service identification and cross-connection details should be entered in **PENCIL** (HB, B or 2B) so that they can be erased and re-entered.

Figure 15 Typical customer MDF records

### Earthing of MDFs

The lead-in termination backmounts of the MDF should be equipotentially bonded to the electrical earthing system in accordance with Australian Standard AS/ACIF S009:2006 (wiring rules) to facilitate the installation of effective surge suppression for the protection of the end-users of the telecommunications services.

The total length of conductor between the MDF backmounts and the earthing bar or terminal in the electrical switchboard should be no more than 1.5 metres where practicable, but must not exceed 10 metres in any case. This means if the equipotential bonding conductor is connected to the earth electrode, the length of the main earthing conductor between the electrode and the main earthing bar or terminal in the switchboard must be deducted from 1.5 metres (or 10 metres if 1.5 metres cannot be achieved) to determine the maximum allowable length of the bonding conductor. This is explained pictorially in Figure 16.

The bonding conductor may be connected to a suitable earthing bar or terminal at the MDF or it may be connected directly to the lead-in termination backmount. Where Profil backmounts are used, ensure that both mounting rods are earthed. Each lead-in termination module will be fitted with Profil earthing clips (by Telstra) as shown in Figure 20 where an ADC KRONE arrester magazine is used.

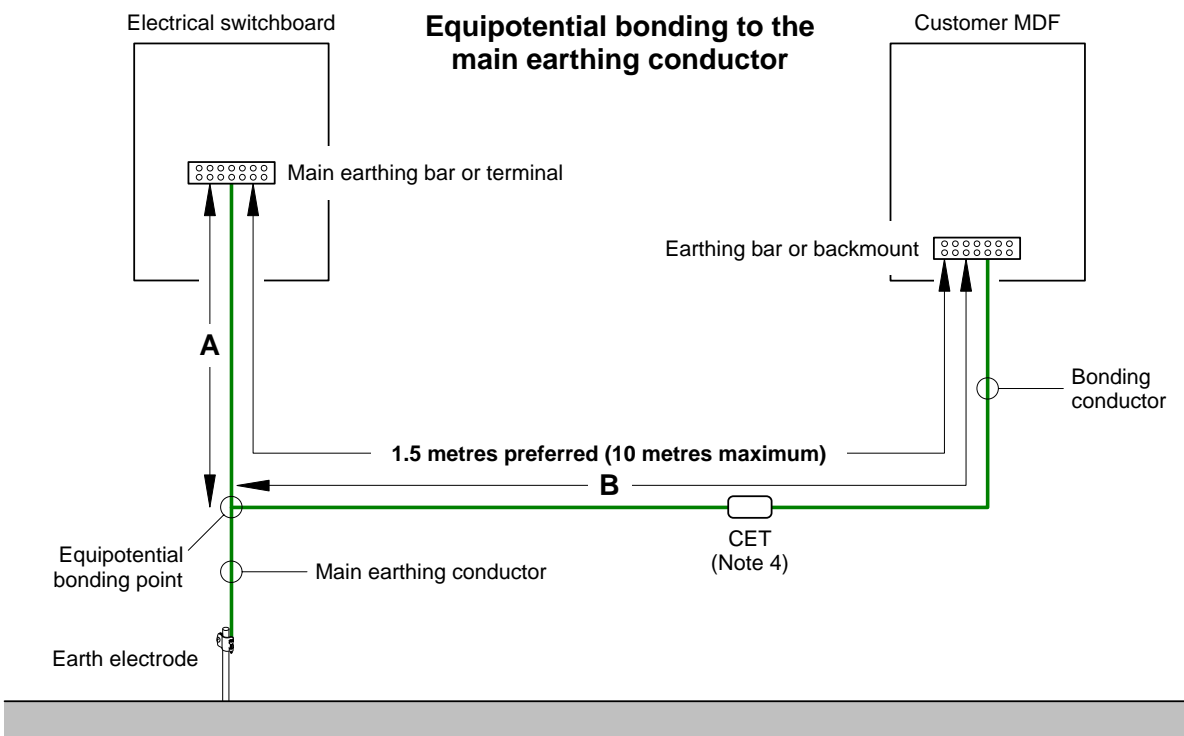
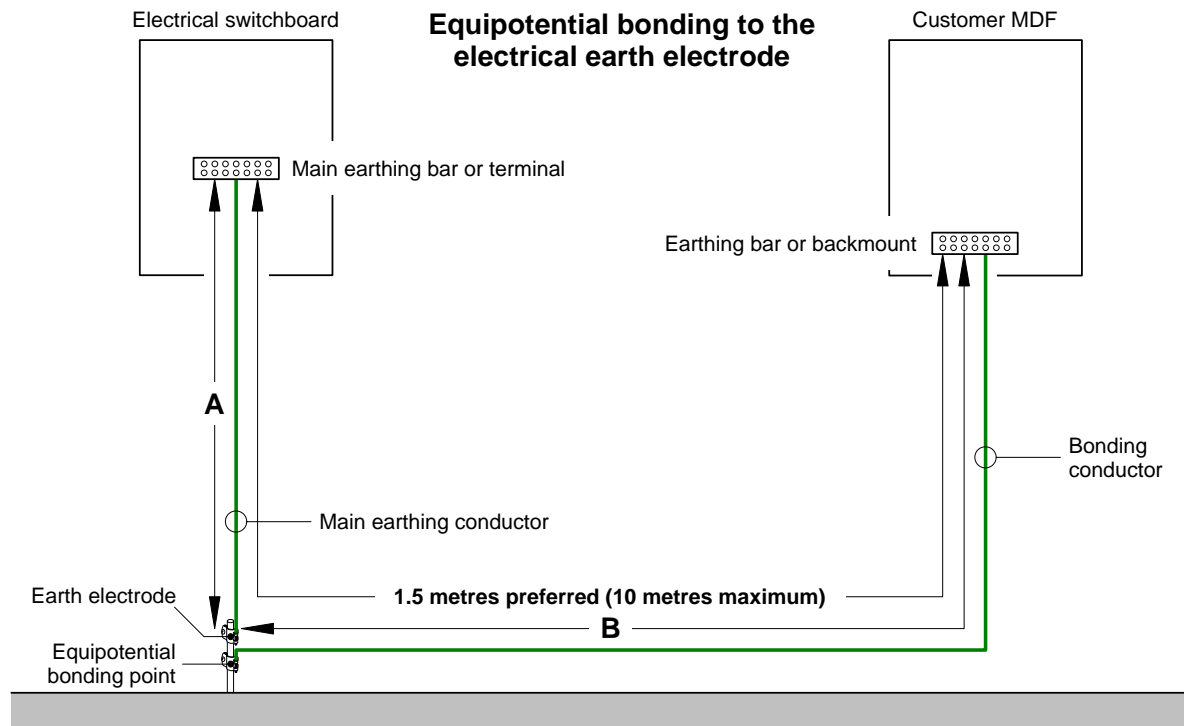

## Notes:

1. In each of the above cases, **A** = the length of the main earthing conductor between the main earthing bar or terminal and the equipotential bonding point, while **B** = the maximum allowable length of the bonding conductor between the equipotential bonding point and the MDF.
2.  $B = 10 - A$  (in metres). Thus if  $A = 1.5$  metres,  $B = 10 - 1.5 = 8.5$  metres. In most cases, the cabling provider will have to estimate the value of **A** based on the location of the switchboard in relation to the earth electrode.
3. If the equipotential bonding point is the earthing bar/terminal in the switchboard,  $A = 0$ , so  $B = 10$  metres.
4. The CET (Communications Earth Terminal) may be located in any convenient position (including inside the MDF) but must not be located inside the electrical switchboard.

**Figure 16** Calculating the maximum permissible length of the bonding conductor

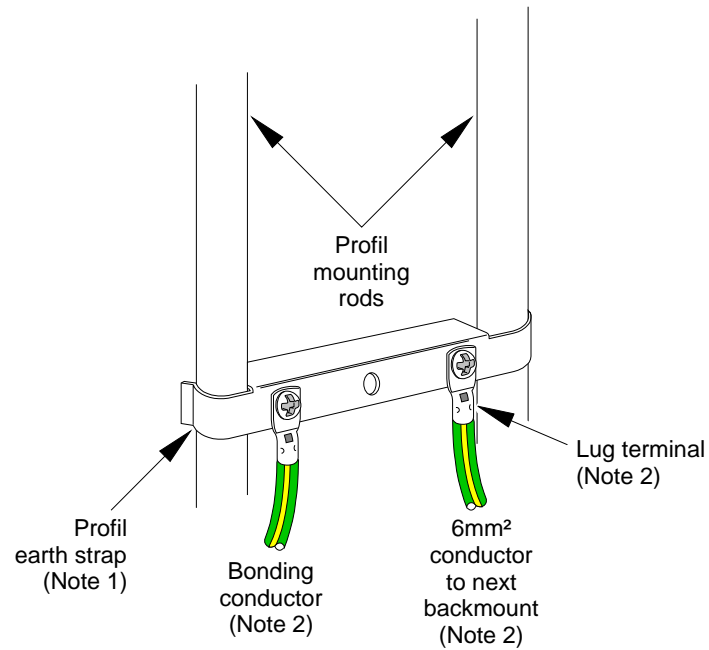

Notes:

1. Use ADC KRONE Profil earth strap (ADC KRONE Product No. 6455 2 042-00) to earth the backmount rods. This strap is normally supplied with the ADC KRONE 100-pair backmount frame but is also available separately.
2. Crimp a lug terminal to the bonding conductor and secure it to the earth strap with a suitable bolt using a star washer or lock washer between the nut and the strap. Where two or more backmounts are to be earthed, bond them together using a 6 mm<sup>2</sup> green/yellow conductor. Spade (forked) terminals must **NOT** be used for termination of earthing conductors.
3. Where the backmount rods are supported by a metal bracket, the metal bracket may have screw terminals for connection of earthing conductors. In this case, the Profil earth strap is not required — simply terminate the bonding/earthing conductor(s) on the metal support bracket.

Figure 17 Bonding/Earthing of Profil style ADC KRONE module backmounts

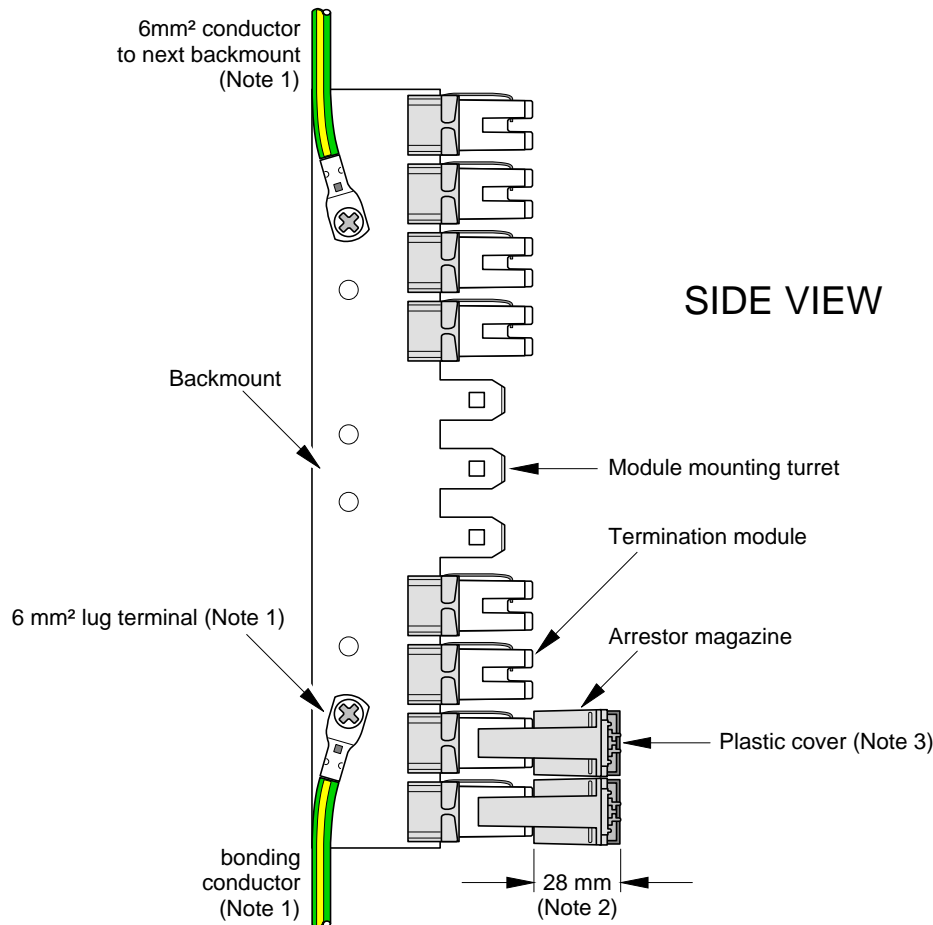

## Notes:

1. Crimp a lug terminal to the bonding conductor and secure it to the backmount with a suitable bolt using a star washer or lock washer between the nut and the backmount. Where two or more backmounts are to be earthed, bond them together using a 6 mm<sup>2</sup> green/yellow conductor. Spade (forked) terminals must **NOT** be used for termination of earthing conductors. The bonding conductor and other earthing conductors may be fastened on the inside or outside of the backmount, whichever is convenient.
2. MDFs are required to have a minimum clearance of 30 mm between the front face of the lead-in termination modules and the inside face of the door or cover of the MDF. This is to allow room for fitting of arrestor magazines.
3. The ADC KRONE arrestor magazine is supplied with a clear plastic cover, which must be fitted to the installed magazine to prevent accidental human contact with the “live” arrestors.

Figure 18 Bonding/Earthing of turret style ADC KRONE module backmounts

## Surge suppression

### General

ADC KRONE arrestor magazines are used to provide customer lightning protection (CLP) at customer MDFs and are plugged into the front of ADC KRONE Series 2 Disconnection modules. In designated high lightning risk situations, the arrestor magazine will be fitted on the “A” side of the MDF by Telstra at Telstra’s cost. In other circumstances, the lightning surge suppression must be installed on the “B” side of the MDF by the cabling provider at the customer’s cost.

The standard Telstra ADC KRONE arrestor magazine (ADC KRONE Product No. 6462 2 099-00) uses 500 V gas arrestors.

Note: 230 V ADC KRONE arrestor magazines are available (ADC KRONE Product No. 6462 2 053-10) and may be used at a customer MDF. However, while these may provide slightly better surge protection for equipment, they do not significantly improve the level of end-user protection and the lower firing voltage increases the safety risk to the Telstra network under electrical power system fault conditions.

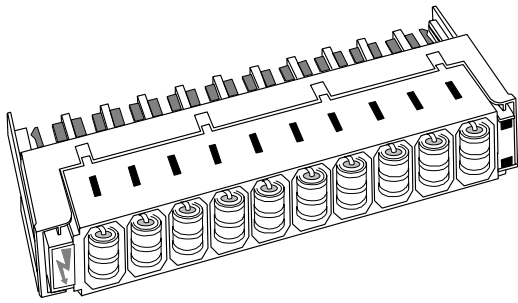

## Notes:

1. The standard arrester magazine used by Telstra contains 500 V protectors and may be used to provide lightning surge suppression at either the customer MDF or other distributors on the customer's side of the MDF. An arrester magazine with 230 V protectors is also available but may only be used to provide surge suppression at a customer MDF.
2. The arrester magazine is supplied with two Profil clips for insertion into the termination module to which the arrester magazine is to be fitted and where a Profil backmount is used (see Figure 20). The kit also includes a clear plastic cover, which must be fitted to the installed magazine to prevent accidental human contact with the uninsulated protectors.

Figure 19 ADC KRONE arrester magazine

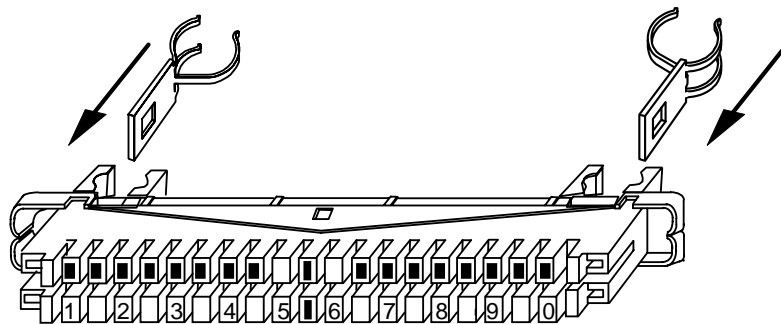

Figure 20 Fitting Profil earthing clips to an ADC KRONE termination module

### Backmount earthing

Ensure that the metallic backmount is connected to the bonding conductor as described on pages 24 to 27. There are three different types of ADC KRONE module backmount or mounting to be considered:

- Profil type (i.e. mounting rods) — see Figure 17
- turret style (i.e. U-shaped sheet metal with mounting tongues) — see Figure 18
- 10-pair MDF (the modules are moulded into the plastic base, but only the “A” side module has a metal fitting that the arrester magazine can connect to). The bonding conductor is connected to the earth terminal, which in turn is bonded behind the MDF base to the metal turret at the lower end of the “A” side module. See Figure 8.

Note: A similar distribution box to the ADC KRONE 10-pair MDF is available but must not be used as an MDF or for installation of surge suppression because:

- ⇒ it does not have a metal turret for earthing of an arrester magazine; and
- ⇒ the cover of this box is not deep enough to fit the arrester magazine.

### Running jumpers where an arrester magazine is fitted

The arrester magazine must be removed from the termination module to connect jumpers or test cords. Unplug the arrester magazine by pulling it straight out with even force at both ends of the magazine.

Don't forget to plug the magazine back into the module after the jumpering or testing is done!

## Obsolete solder-tag MDFs

### General

Solder tag distribution boxes and frames were used to terminate lead-in cabling well into the 1980s and probably right up to “deregulation” of premises cabling in 1989. There are still many of these in service. Cabling providers will often need to connect cables and jumpers to solder tag boxes and frames.

Solder tags make reliable connections as long as the conductors are terminated and soldered correctly. A typical solder tag terminal block is illustrated in Figure 21. The fanning strips behind the terminals vary, depending on whether the terminal block is mounted on a timber batten/backboard (per Figure 22) or on metal framework (per Figure 23).

The correct method and two common, but incorrect, methods of terminating cables and jumpers on solder tag terminals are shown in Figure 24.

All connections on solder tag terminals **MUST** be soldered.

The connection should be soldered using a 30 watt to 45 watt soldering tool with a 6 mm (1/4”) to 8 mm (5/16”) bit. Apply a little solder to the tip of the soldering bit first, then press the tip of the iron flat against the underside of the end of the tag and apply resin cored solder (65% tin, 35% lead) to the “V” in the terminated conductor (see Figure 25).

Examples of good and bad soldering are shown in Figure 26. To achieve an “acceptable connection” shown in Figure 26, it is important that the terminal be clean in the first place and that not too much heat be applied — just enough for the solder to flow smoothly into the crevices.

### Link mounting frames

The solder tags in link mounting frames are different to the terminal blocks described above and a different terminating method is used for the cable connections (see Figure 27). However, for jumpers, use the same terminating method prescribed for other types of solder tags (as shown in Figure 24).

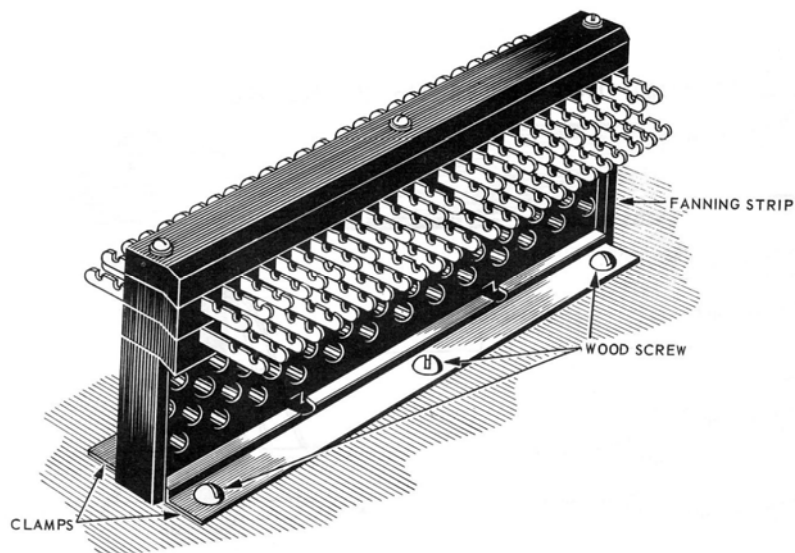
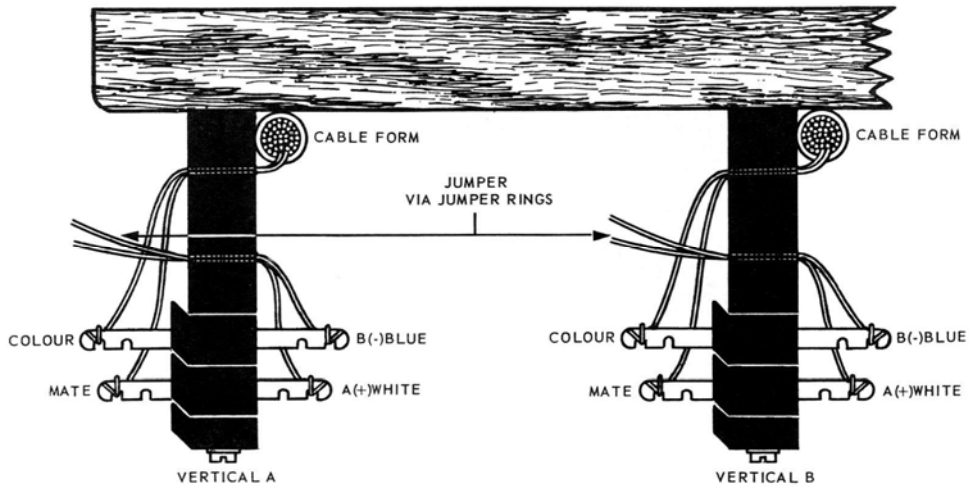
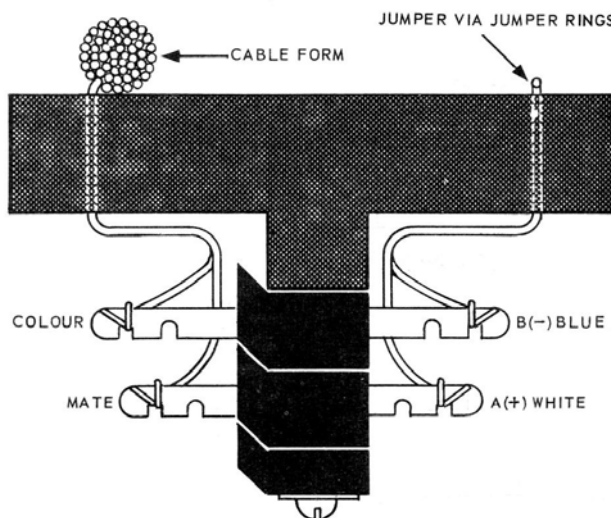

Figure 21 A typical solder tag terminal block (obsolete)



Note: If the distribution box only has two verticals, the cables are usually terminated on the inside terminals and the jumpers run directly (without jumper rings) between the outside terminals. Ensure that sufficient slack is left in the jumpers (25 mm to 50 mm with these boxes) to enable them to be traced.

Figure 22 Solder tag terminal block used in wall mounted distribution boxes



Notes:

1. These terminal blocks are usually mounted on metal framework secured to the wall or floor.
2. Leave sufficient slack in the jumpers (50 mm to 100 mm with these frames) to enable them to be traced.

Figure 23 Solder tag terminal block used in wall mounted or floor mounted distribution frames

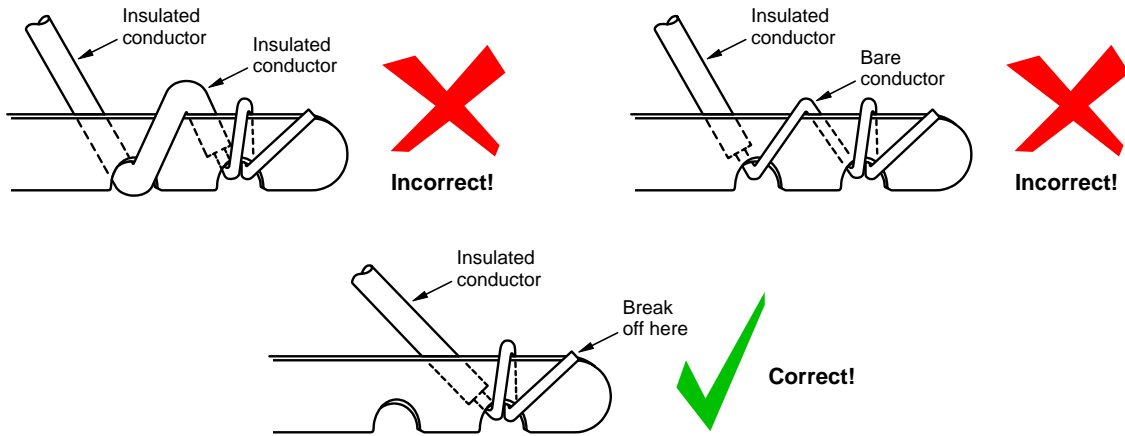
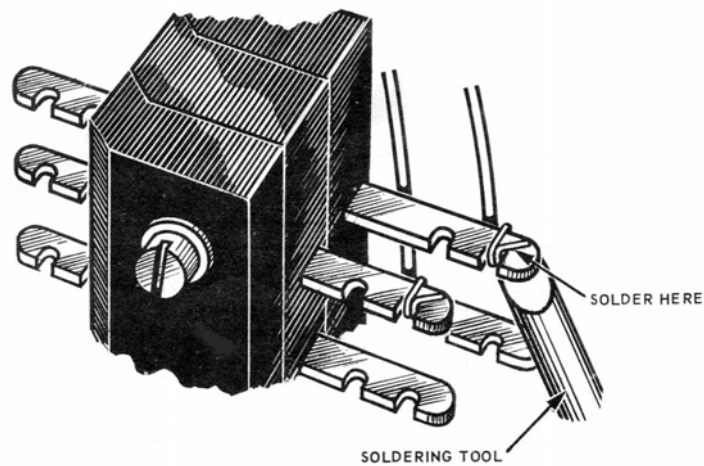

Figure 24 Terminating the conductor on the solder tag



Notes:

1. Use a 30 watt to 45 watt soldering tool with a 6 mm (1/4") to 8 mm (5/16") bit and resin cored solder composed of 65% tin and 35% lead.
2. Apply a little solder to the tip of the soldering bit first, then press the tip of the iron flat against the underside of the end of the tag as shown above.
3. Apply solder to the "V" in the terminated conductor.
4. See Figure 26 for examples of good and bad soldering.

Figure 25 Soldering terminated conductors

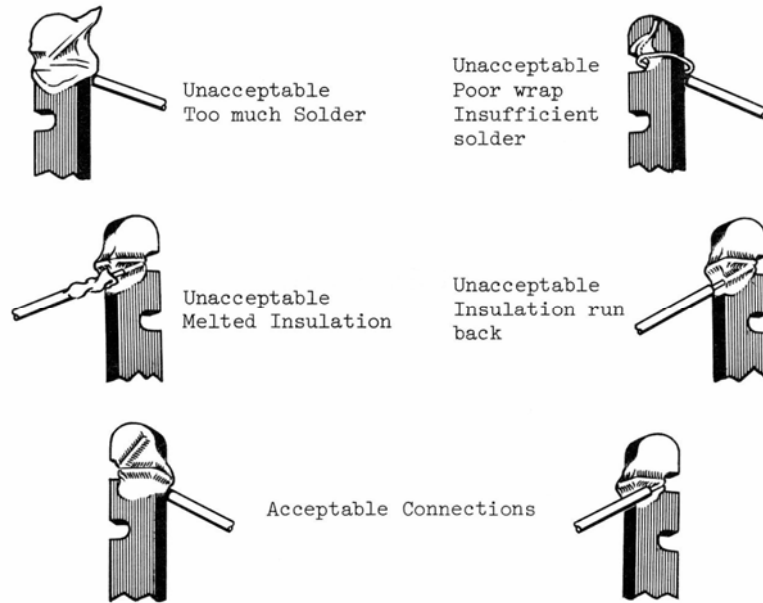
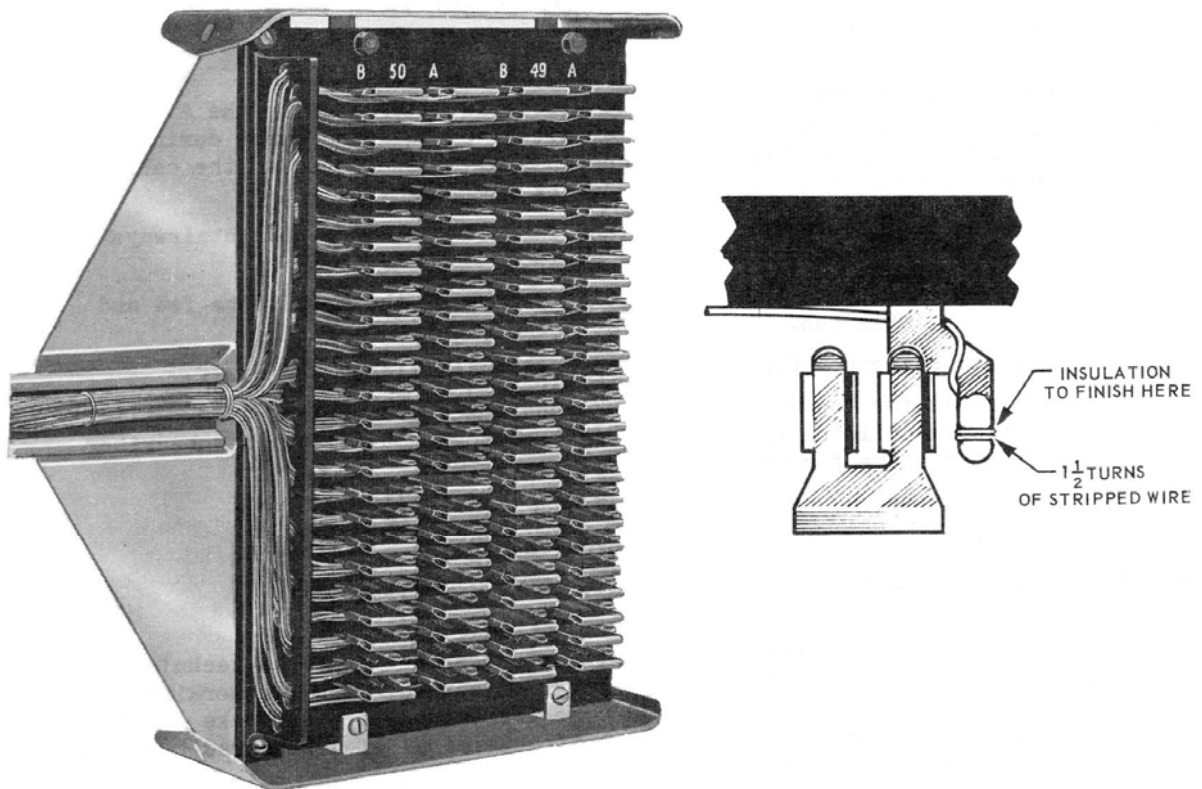

Figure 26 Good and bad soldering



Note: Cables are connected to the link mounting block as shown above. However, jumpers on the other side of the block must be terminated in accordance with Figure 24.

Figure 27 Link mounting frame

## Other obsolete termination equipment

Small screw terminal boxes were used prior to “deregulation” in 1989 for connection of several services to small businesses or blocks of flats/units.

These are **NOT** MDFs, nor are they NTDs. They are lead-in cable jointing devices. The following information is included in this document for completeness only.

The 5-pair and 10-pair screw terminal blocks pictured in Figures 28 and 29 were made of black bakelite and had a slide-on or clip-on metal cover with a record card holder on the inside of the cover. These blocks were designed for indoor use only and may be encountered in some old residences and small businesses. The correct method of terminating conductors on these screw terminal blocks is illustrated in Figure 30.

A later style of screw terminal box, made from ivory or grey plastic, is shown in Figure 31. It was designed to terminate conductors without the need to strip the conductor insulation. The end of the insulated conductor is inserted under one side of the screw and the screw tightened. The conductor should not be wrapped around the screw with this box or effective connection may not be made.

These screw terminal devices are **NOT** MDFs or NTDs and are **NOT** a network boundary point. However, a cabling provider is authorised to disconnect an existing indoor cable and reconnect a replacement cable to the device in accordance with Telstra Specification 012882, “Alteration of Telstra Facilities in Homes and Small Businesses — Information for Cabling Providers”, which may be accessed on the Telstra Smart Community web site [www.telstra.com.au/smartcommunity/](http://www.telstra.com.au/smartcommunity/) (look under “Builders”).

Where a faulty block/box needs to be replaced, the matter should be referred to Telstra. Telstra may choose to replace the faulty block/box with a suitable joint or, if the customer/s is/are agreeable **AND** the position of the block/box meets the current requirements for the location of a customer MDF, replace it with a small MDF, in which case it will then become a valid network boundary point.

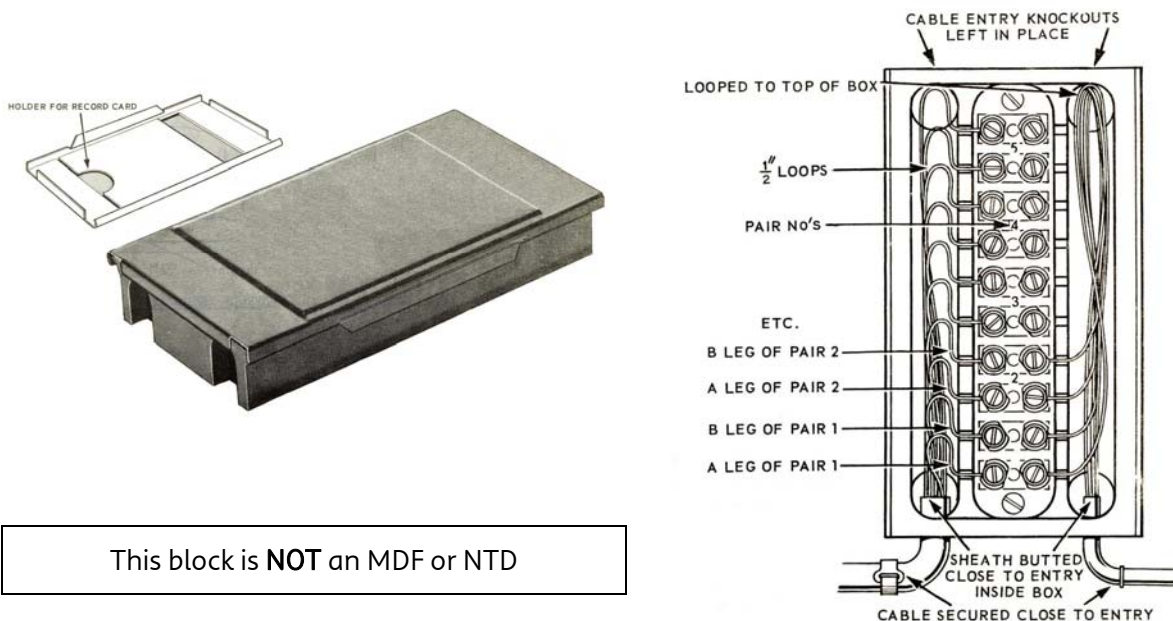

This block is **NOT** an MDF or NTD

Note: This block was used to connect a 5-pair cable to two or more smaller cables (e.g. to connect two or more services to a small business or to connect services to two or more shops, units or flats). Only one conductor should be terminated under each screw as shown in Figure 30.

Figure 28 5-pair screw terminal block (obsolete)

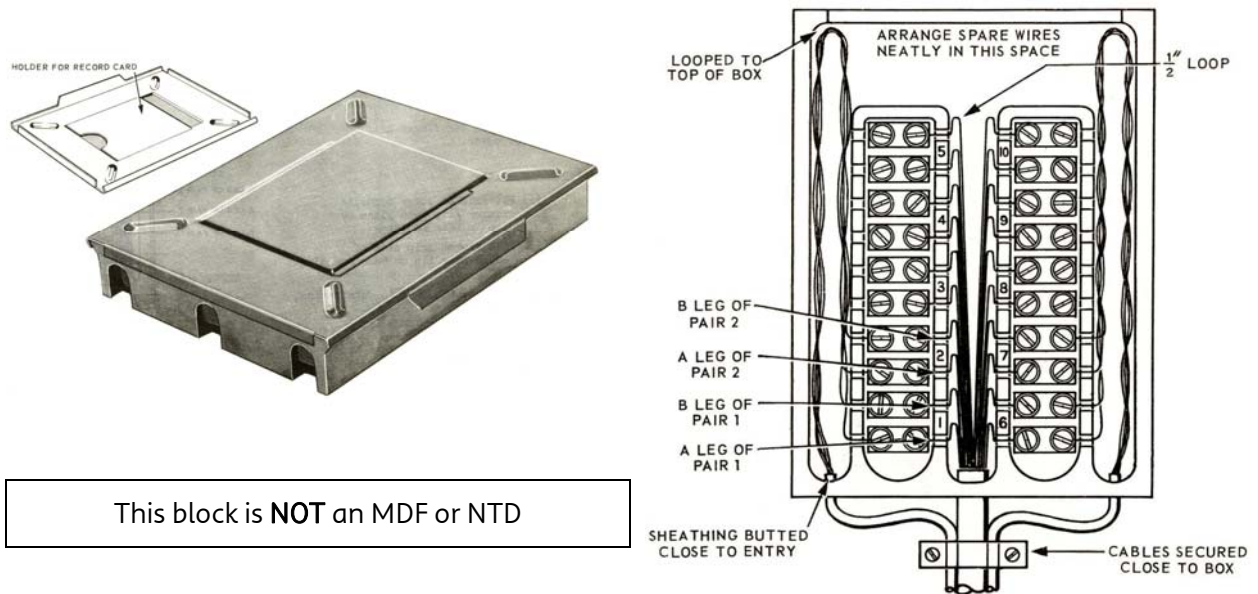

This block is **NOT** an MDF or NTD

Note: This block was used to connect a 6-pair or 10-pair cable to two or more smaller cables (e.g. to connect two or more services to a small business or to connect services to two or more shops, units or flats). Only one conductor should be terminated under each screw as shown in Figure 30.

Figure 29 10-pair screw terminal block (obsolete)

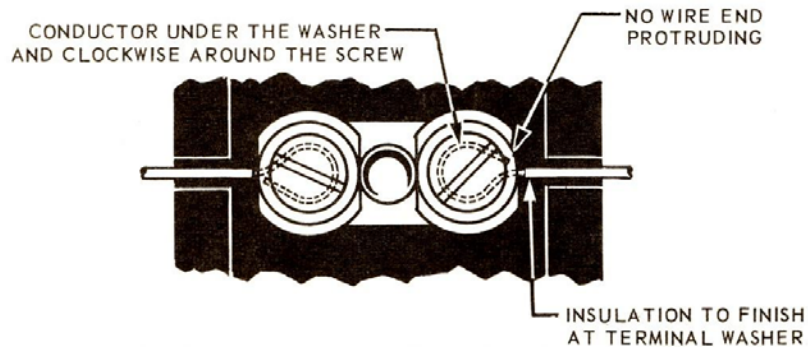

Note: Only one conductor should be terminated under each screw. If more than one conductor needs to be terminated under the screw, twist the bare conductors together before wrapping them around the screw and **LIGHTLY** tighten the screw (overtightening the screw may sever one or more of the twisted conductors).

Figure 30 Terminating conductors on screw terminal blocks

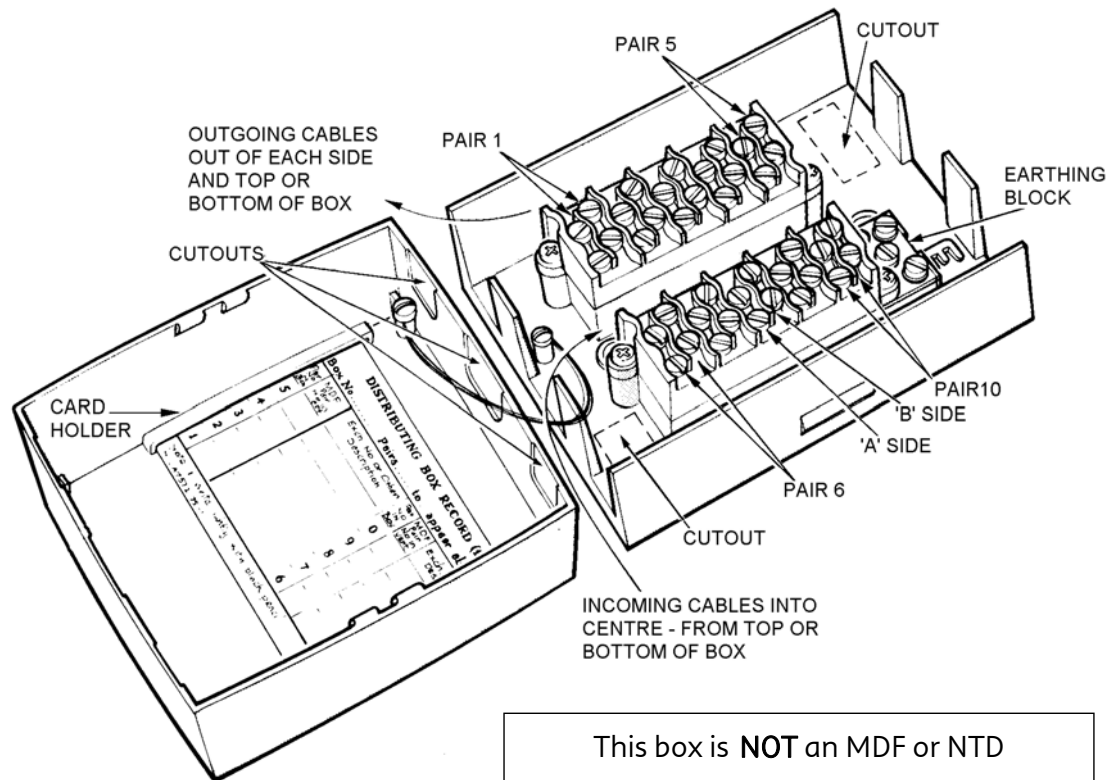

## Notes:

1. This box was used to interconnect several cables (e.g. to connect two or more services to a small business or to connect services to two or more shops, units or flats).
2. With this box, the insulated conductor must be inserted under one side of the screw and the screw tightened. Do **NOT** wrap the conductor around the screw or proper connection may not be made. Only one conductor should be connected to each screw.

Figure 31 Insulation crushing screw terminal box (obsolete)

## Contacting Telstra

### New MDF

Where it is necessary to contact Telstra for advice about the installation (e.g. location) of a **NEW** MDF or to get the Telstra lead-in cable terminated on the MDF, please call the appropriate number listed below and follow the procedure listed.

Home .....	13 2200
Business .....	13 2000

- To the automated voice greeting, respond “Connections”, then “Home” or “Business”, as applicable.
- Tell the Telstra consultant that you are ringing about the installation of, or the connection of Telstra lead-in cabling to, an MDF at your premises.
- Tell the Telstra consultant your name, contact number and the address to which the enquiry is related. If you were previously given a job number when arranging pre-provisioning or an order number when requesting a new service, quote this number.
- The Telstra consultant may provide you with a reference number for any follow-up enquiries.

### MDF alterations

For relocation of an **EXISTING** MDF or associated lead-in cabling (e.g. due to building renovations or land redevelopment), please call the number listed below and select the appropriate option.

Home or Business .....	1800 810 443
------------------------	--------------

You will receive an automated voice greeting giving the following options:

- Press **1** to lodge a new request for relocation of an existing MDF and/or associated lead-in cabling.
- Press **2** for follow-up enquiries about a request that has previously been lodged.

You will be switched through to the Telstra Non Standard Works Team for your area with which you may discuss your requirements.

oooOooo