

Cabling of multi-building residential developments



This publication has been prepared and written by Telstra Corporation Limited (ABN 33 051 775 556), and is the subject of copyright. Other than for the purposes of and subject to the conditions prescribed under the Copyright Act, no part of it may in any form or by any means (electronic, mechanical, microcopying, photocopying, recording or otherwise) be reproduced, stored in a retrieval system or transmitted without prior written permission of Telstra. Product or company names are trademarks or registered trademarks of their respective holders.

Note for non-Telstra readers: The contents of this publication are subject to change without notice. All efforts have been made to ensure the accuracy of this publication. Notwithstanding, Telstra Corporation Limited does not assume responsibility for any errors nor for any consequences arising from any errors in this publication.

Introduction

This document provides property developers an outline of Telstra's requirements for the provision of telecommunications cabling within multi-building, multi-tenant premises to enable the supply of telecommunications services to the occupants. It applies to private property residential developments such as villas, town houses and retirement villages.

This document may be downloaded from the Telstra Smart Community® web site www.telstra.com.au/smartcommunity/ (look under "Builders").

Telstra's preferred cabling method for multi-dwelling premises

Telstra recommends that the property developer, on behalf of the future occupants of the premises, provides suitable trenching between the Telstra property entry point (PEP) and the Telstra building entry point (BEP) at each building. Trenching should be supplied wherever practicable during the development phase in order to minimise:

- future disruption to roads, driveways, footpaths and landscaping;
- expense and inconvenience for the occupants in providing future trenching for the supply of telecommunications services; and
- the time taken to provide new telecommunications services to the occupants.

Once suitable trenches are provided, Telstra will supply and install the appropriate conduits, pits and cables to service the development.

An example of this preferred method is shown in Figure 1. Telstra prefers to cable to each building to:

- ensure that the occupants have access to the greatest range of services available; and
- enable Telstra to readily maintain and upgrade its networks in the future.

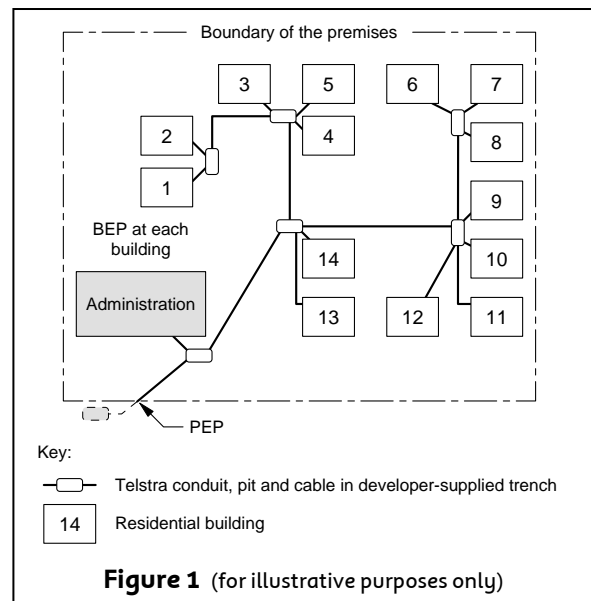

® Registered trade mark of Telstra Corporation Limited ABN 33 051 775 556

Private cabling

In some premises, private cabling may be required between buildings for such purposes as security, nurse call or operation of a central PABX. While Telstra does not have an issue with the installation of such cabling, due to service complications beyond Telstra's control, Telstra will not rely on the use of private cabling between buildings to supply Telstra services to the occupants.

Telstra prefers to provide its own network cabling within the development whether or not private cabling is to be provided. Apart from the trenching requirements described above, the Telstra network cabling will be installed and maintained at Telstra's cost for the purpose of supplying Telstra services. The Telstra cabling and the private cabling must be totally separate, i.e. using separate conduits, pits and cables, but may share the trenching.

Telstra will not:

- use conduits (shared or otherwise) installed for private purposes to supply a Telstra service; or
- allow non-carrier cabling to be installed in Telstra conduits and pits; or
- allow Telstra cables to be used for intra-premises communications purposes.

Where a central PABX is to be installed to supply services to occupants, Telstra will provide sufficient lines to the central PABX to cater for the number of services required by the operator of the PABX. However, it remains Telstra's preference to also provide its own network cabling to each building.

If an occupant applies to Telstra for the direct supply of a Telstra service and Telstra network cabling has not been installed to the occupant's building, then trenching between the Telstra PEP and the occupant's building may be required, resulting in disruption, expense and delays as described above.

Trenching requirements

The technical specifications for customer-provided trenches between the BEP and PEP are provided in Telstra Document No. 017153a07, "Telstra's lead-in trenching requirements". This document may be downloaded from the Telstra Smart Community web site www.telstra.com.au/smartcommunity/.

Planning ahead

While this paper outlines Telstra's basic policy, we recognise that each development is different. Early consultation can help ensure a solution that benefits all parties.

More information

For more information about cabling of your development, go to the Telstra Smart Community web site www.telstra.com.au/smartcommunity/ and look under the "Builders" menu.

Our Customer Terms may be found at www.telstra.com.au/customerterms/.

Meaning of terms used in this document

The following words have the following special meanings.

Building means a substantial structure with a roof and walls, and includes a high-rise building, block of flats/apartments, factory, house, shed, caravan and mobile home.

Building entry point (BEP) is the point where Telstra's lead-in cable meets the outer surface of the building.

Premises means land together with its building or buildings.

Property entry point (PEP) means, for the purpose of this paper, the point where Telstra's cable enters the land occupied by the customer, including any land occupied in common with other occupants.

oooOooo